

INSTALLATION

EN

Loria 6000 R32

Air/water heat pump single service split system

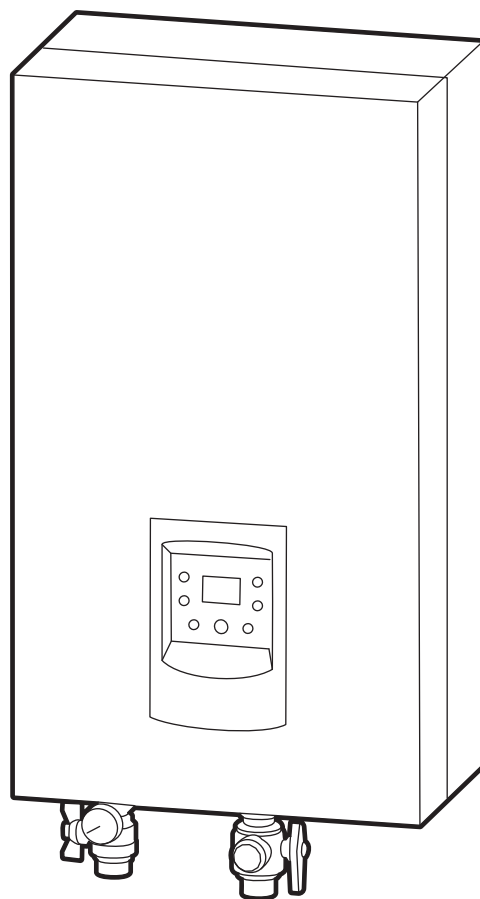
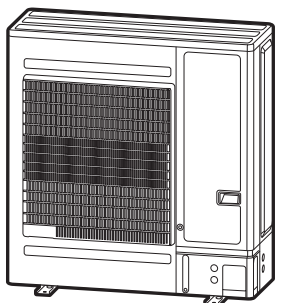
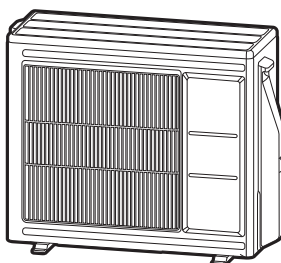
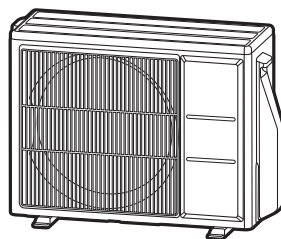

Outdoor unit

WOYA060KLT

WOYA080KLT

WOYA100KLT

Hydraulic unit

023015

023016

024158



U0710280_2256_EN_4
05/09/2022

For professionals
To be kept by the user for future reference



■ Installation and maintenance rules

The appliance must be installed and maintained by an approved professional in accordance with the prevailing regulations and code of practice, in particular:

- **Do not use any means to accelerate the defrosting process or to clean the appliance, other than those recommended by the manufacturer.**
- **The appliance must be stored in a room that does not contain continuously operating ignition sources (for example: open flames, gas appliance or operating electric heater).**
- **Do not pierce or burn.**
- **Be careful, refrigerants can be odorless.**

■ Handling

The outdoor unit must not be in a horizontal position during transport. Transport in a horizontal position may damage the appliance by moving the refrigerant and damaging the compressor's suspensions. **Damage caused by transportation in a horizontal position is not covered by the warranty.**

If necessary, the outdoor unit may be tilted during manual handling (to go through a door or use a staircase).

This operation must be conducted very carefully and the appliance must be immediately restored to the upright position.

■ Installation

The heat pump installation must meet the requirements related to the location of the heat pump.

The heat pump is designed to be installed at less than 2000 m altitude.

In accordance with IEC 60-335-2-40 standard, the hydraulic module of the heat pump as well as all the refrigerant connections that cross the inhabited area must be installed in rooms respecting the minimum surface.

- **Warning, hydraulic unit should not be installed in an air current.**

■ Refrigerant

The maximum R32 fluid load after refilling must not exceed 1.84 kg.

■ Containment of refrigeration circuits

All refrigeration circuits are sensitive to dust and moisture contamination. If any such pollutants penetrate the refrigeration circuit, they can affect the reliability of the heat pump.

- **Make sure that the connections and refrigeration circuits (hydraulic unit, outdoor unit) are protected correctly.**
- **In the event of a subsequent failure and following an inspection, the presence of moisture or foreign bodies in the compressor oil would automatically void the warranty.**
- Check upon receipt that the fittings and refrigeration circuit caps mounted on hydraulic unit and outdoor unit are properly seated and secured (cannot be loosened with bare hands). If this is not the case, tighten them using a C spanner.
- Check also that the refrigeration connections are sealed (plastic caps or tubes crimped at the ends and brazed). If the caps must be removed during the installation (tubes to be re-cut for example), put them back as soon as possible.

■ Hydraulic connections

The connection must comply with good engineering practices according to the regulations in force.

Reminder: Make the assembly seals according to good engineering practices in force for plumbing work:

- Use suitable seals (fibre seals, O rings).
- Use Teflon or hemp tape.
- Use sealant (synthetic as required).

Reminder: The presence on the installation of a CB disconnection function (IEC 61770), designed to avoid heating water from returning to the drinking water network, is required by articles 16.7 and 16.8 of the Standard Departmental Sanitation Rules.

Glycol must be used if the initial temperature is less than 10°C (cooling on the fan-coil heater). If water containing glycol is used, carry out an annual check of the quality of the glycol. Use monopropylene glycol only. **Never use monoethylene glycol.**

In certain installations, the presence of different metals can cause corrosion problems; in this case, the formation of metal particles and sludge in the hydraulic circuit is seen. Use a corrosion inhibitor in the proportions recommended by its manufacturer.

It is also necessary to ensure that the treated water does not become aggressive.

Place on the cold water supply a security unit with calibrated valve 7 to 10 bar max. (depending on local regulations), which will be connected to the sewer vent. Operate the safety unit according to the manufacturer's specifications. There should be no valve between the safety unit and the tank.





■ Characteristics of the electrical power supply

Always check that the electric power supply is switched off before works.

The electrical installation must be conducted in accordance with the regulations in effect and in particular:

The electrical connections will only be made when all of the other assembly operations (attachment, assembly,...) have been carried out.

Warning!

The contract taken out with the energy supplier must be sufficient to cover the power of the heat pump as well as the sum of the power requirements of all of the appliances likely to be operated at the same time. When the power is too low, check with the energy provider the value subscribed to in your contract.

Never use a socket for the power supply.

The heat pump must be directly powered (without external switch) by dedicated lines that are protected from the electrical housing by bipolar circuit breakers dedicated to the heat pump, curve C for the outdoor unit, curve C for the electrical DHW back-ups.

The electrical installation must be equipped with a differential protection of 30 mA.

This appliance is designed to operate under a nominal voltage of 230 V +/- 10%, 50 Hz.

■ General remarks on electrical connections

It is essential to maintain the phase-neutral polarity when making the electrical connections.

Rigid wires are preferable for fixed installations, particularly in a building.

Clamp the cables using cable clamps to avoid any accidental disconnection of the conductive wires.

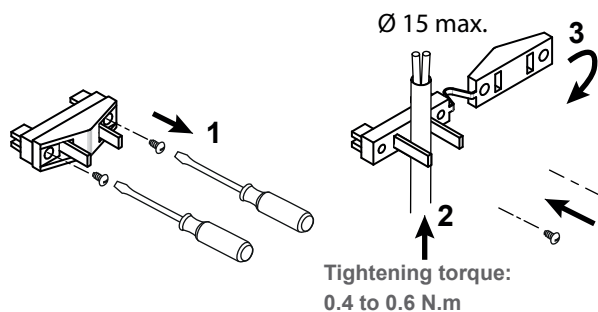

Connection to Earth and Earth bonding continuity are essential.

• Connecting to screw terminals

Use of ring terminals or tips is prohibited.

- Always choose a rigid wire that complies with current standards.
- Strip the end of the wire over a length of around 25 mm.
- With round nosed pliers, make a loop with a diameter that corresponds to the terminal's tightening screws.
- Tighten the terminal screw on the loop very firmly. Insufficient tightening can cause overheating, leading to breakdown or even a fire.

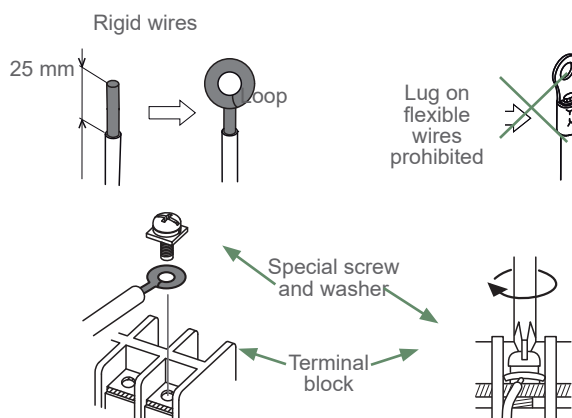

• Connecting to spring terminals

- Strip the end of the wire over a length of around 10 mm.
- Push the spring with a screwdriver so that the wire enters the cage.
- Slide the wire into the opening provided for this purpose.
- Remove the screwdriver and then check that the wire is jammed in the cage by pulling on it.

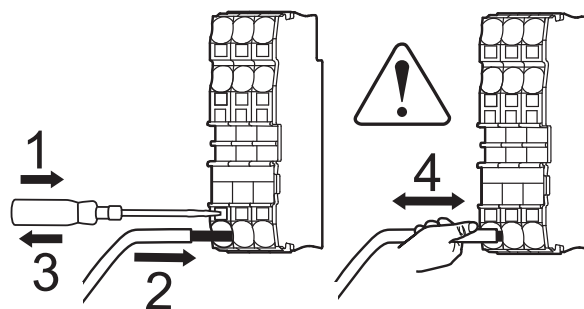
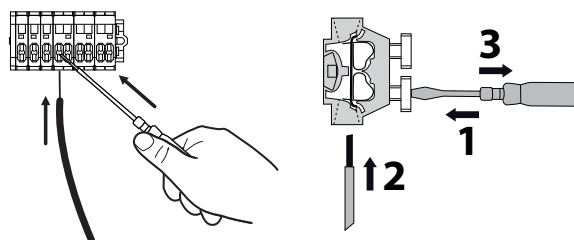









This device must be installed by qualified personnel with a certificate of capacity for the handling of refrigerants.



Any modification or work on the device not authorised by the manufacturer will automatically void the warranty.

Contents

Q	Description of the equipment	6
	Packaging	6
	Definitions	6
	Scope	6
	Optional equipment	6
	Specifications	7
	Description	11
	Operating principle	13
🏠	Layout	14
	Positioning the refrigerant connections	14
	Installing the outdoor unit	15
	Installation of the hydraulic unit	18
↻	Refrigeration connections	26
	Rules and precautions	26
	Shaping the refrigeration pipes	26
	Checks and connection	29
	Collecting refrigerant in the outdoor unit	31
💧	Hydraulic connections	32
	Rinsing the installation	32
	Connections	32
	Filling and draining the installation	33
🔧	Electrical connections	34
	Electrical power connections (LV)	35
	Electrical connections - SELV	42
🧑‍💻	Controller Interface	44
	User interface	44
	Display Description	45
🌡️	Temperature control	46
	Configuration	46
	Room influence	46
	Room control	46
⚙️	Commissioning	48
	Checks before commissioning	48
	Commissioning	48
	Cleaning the filter valve	49
	Circulation pump operation	49
	Floor drying mode	49
🏠	Controller Menu	50
	Overview	50
	Setting parameters	50
	List of parameters	51
	Displaying information	56

 Troubleshooting	58
Hydraulic unit errors	58
Outdoor unit errors	60
 Maintaining the installation	64
Hydraulic checks	64
Checking the outdoor unit	64
 Maintenance	65
Draining the hydraulic unit.	65
Replacing fuses.	65
 Appendices	66
Filling the installation with gas.	66
Overall hydraulic layout.	68
 Quick-start procedure	76
Commissioning check-list	76
Settings sheet	78
 Instructions for the user	79

 This document was written in French and translated.

 Read the document comprising the precautions for use (regulation installation and maintenance conditions) before installation and/or use.

► Symbols and definitions

	Warning. Risk of serious injury to the person and / or risk of damage to the machine. Observe the warning.		Warning : Electricity hazard
	Important information that must always be kept in mind.		Warning : Slightly flammable refrigerant.
	Tips and advice		Read the installation manual
	Bad practice		Read the operating manual
			Read the installation and operating manuals





Q Description of the equipment

► Packaging

Packing list

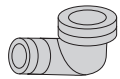
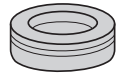
Heat pump			Outdoor unit		Hydraulic unit	
Model	Code (export)	Code (NL)	Model	Code	Model	Code
Loria 6004 R32	526117	924040	WOYA060KLT	700227	Loria 4 R32	023015
Loria 6006 R32	526118	924041			Loria 6-8 R32	023016
Loria 6008 R32	526119	924041	WOYA080KLT	700228		
Loria 6010 R32	526120	924050	WOYA0100KLT	700229	Loria 10 R32	024158

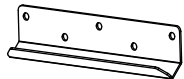
- **1 package:** Outdoor unit
- **1 package:** Hydraulic unit, filter valve, pressure gauge valve.

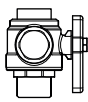
Accessories	
	Adapter 5/8" - 1/2" and/or 3/8" - 1/4" * Nut 5/8" and/or 3/8" *
	Elbow *
	Plug X 3 *
	Cable grommet X2
	Bracket
	Pressure gauge valve with bleed tap
	Filter valve

* Only models 10

► Definitions

- **Split:** The heat pump is formed by two elements (an outdoor unit to be installed outdoors and a hydraulic unit to be installed indoors).
- **Air/water:** The outdoor air is the energy source. This energy is transmitted to the heating water by the heat pump.
- **Inverter:** The speeds of the fan and the compressor are modulated to suit the heat requirements. This technology saves energy and permits operation with a single phase power supply, regardless of the power rating of the heat pump, by avoiding high current demands on start-up.
- **COP** (coefficient of performance): this is the ratio between the energy transmitted to the heating circuit and the electrical energy consumed.

► Scope

This heat pump provides:

- heating in winter,
- control of two heating circuits*,
- production of domestic hot water* (provided that combined with a DHW tank),
- cooling in summer* (for floor heating/cooling system or fan-coil unit).

*: These options require the use of additional kits (see § "Optional equipment").

► Optional equipment

- **Room thermostat Navilink 105** (ref. 074 511) / **Navilink 128** (ref. 074 513)
for correcting the ambient temperature.
- **HP Pack** (ref. 602 231)
for reporting consumption per use (Heating / DHW).
- **Dual circuit kit** (ref. 076 311)
for connecting 2 heating circuits.
- **DHW kit** (ref. 076 312)
for connecting a DHW tank
(with built-in electrical back-ups).
- **Cooling kit** (ref. 076 313).
- **Sediment trap** (ref. 075 100)
for protecting the heating circuit of the HP
(to be placed on the heating return circuit).
- **Anti-vibration pads** (ref. 523 574).
- **White PVC floor support** (ref. 809 532) or **Black rubber floor support** (ref. 809 536).
- **Condensate drain pan** (Models 4/6/8 - ref. 074 049).
- **Container bottom tracer** (ref. 809 644).
- **Outdoor temperature sensor** (ref. 074 203).

► Specifications

Model name	Loria	6004	6006	6008	6010
Nominal heating performances (outdoor temperature/ initial temperature)					
Heat output					
+7 °C/+35°C - floor heating system	kW	4.60	5.60	7.50	9.80
+7 °C / +55 °C - Radiator	kW	4.50	5.60	7.2	9.50
Power absorbed					
+7 °C/+35°C - floor heating system	kW	0.95	1.16	1.66	2.16
+7 °C / +55 °C - Radiator	kW	1.66	2.02	2.60	3.33
Coefficient of performance (COP)	(+7°C/+ 35°C)	4.83	4.81	4.52	4.53
Electrical characteristics					
Voltage (50 HZ)	V			230	
Maximum current of the appliance	A	11	12.5	17.5	18.5
Maximum current of the electrical back-ups	A			13.05	
Electrical backup heater	kW			3	
Power absorbed by the circulation pump	W			45	
Maximum power absorbed by the outdoor unit	W	3260	3260	4510	4760
Hydraulic circuit					
Maximum operating pressure	MPa (bar)			0.3 (3)	
Minimum allowed hydraulic flow rate	l/h	420	600	600	600
Minimum recommended water volume per circuit (excl. HP)... ¹					
- Floor heating-cooling system	l	15	15	28	35
- Cast iron / steel radiators	l	25	25	46	57
- Dynamic radiator ²	l	36 ⁽²⁾	36 ⁽²⁾	49 ⁽²⁾	62 ⁽²⁾
Expansion vessel contents	l			8	
Miscellaneous					
Weight of hydraulic unit (empty/full of water)	Kg			42 / 46	
Weight of the outdoor unit	Kg	39	39	42	62
Noise level at 1 metre ³ (hydraulic unit)	dB (A)			36	
Sound power level as per EN 12102 ⁴ (hydraulic unit)	dB (A)			40	
Noise level at 5 metres ³ (outdoor unit)	dB (A)	35	35	38	40
Sound power level as per EN 12102 ⁴ (outdoor unit)	dB (A)	57	57	60	62
Heating system operating limits					
Min./max. outdoor temperature	°C	-20 / +35	-20 / +35	-20 / +35	-20 / +35
Max. heating water flow temperature underfloor heating	°C	45	45	45	45
Max. heating water flow temperature low temperature radiator	°C	52	52	52	52
Refrigerant circuit					
Diameters of the gas / liquid pipes	Inches	1/2 / 1/4	1/2 / 1/4	1/2 / 1/4	5/8 / 3/8
Factory charge of refrigerant R32 ⁵	g	970	970	1020	1630
Maximum operating pressure	MPa (bar)	4.2 (42)	4.2 (42)	4.2 (42)	4.2 (42)
Min. / max. length of pipes ^{6/8} / max. length with additional charge ⁷	m	3 / 15	3 / 15	3 / 15	3 / 20
Maximum level difference	m	30 / 20	30 / 20	30 / 20	30 / 20

¹ Min. circulating water volume **required for each circuit** excl. HP volume: see additional information [page 32](#).

² Water volume **to be complied with**, installation of a buffer **required**.

³ Sound pressure level at (x) m from the appliance, 1.5 m from the ground, free field, directivity 2.

⁴ The acoustic power is a measurement made in the laboratory of the power of the noise emitted but contrary to the noise level, it does not correspond to the measurement of what is felt.

⁵ Refrigerant R32 in compliance with standard NF EN 378.1.

⁶ Factory charge of refrigerant R32.

⁷ Taking into account the potential additional charge of refrigerant R32 (see [page 30](#)).

⁸ The announced thermal and acoustic performances are measured with 7,5m length refrigerant lines.

■ Outdoor Unit, models 4, 6

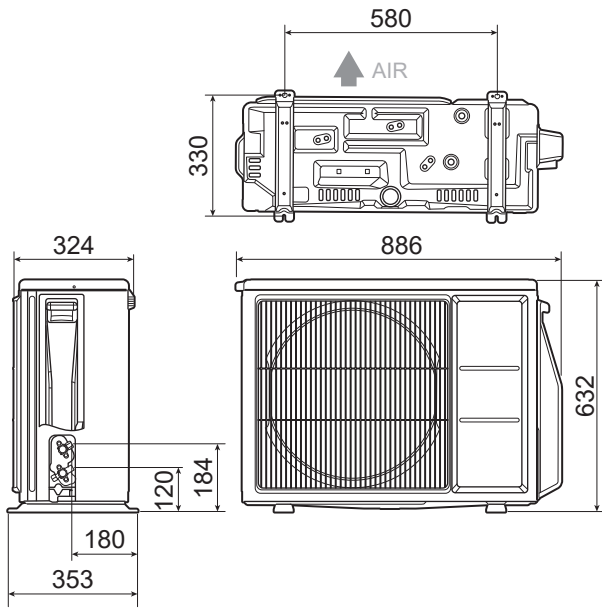

■ Outdoor Unit, model 8

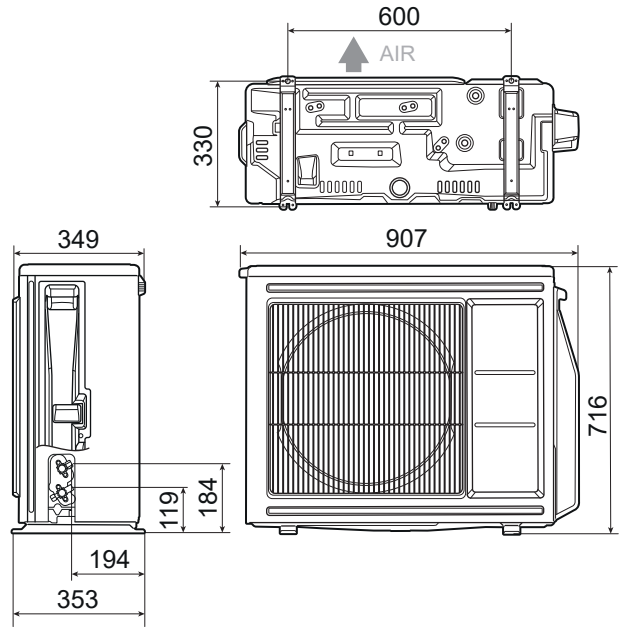

■ Outdoor Unit, model 10

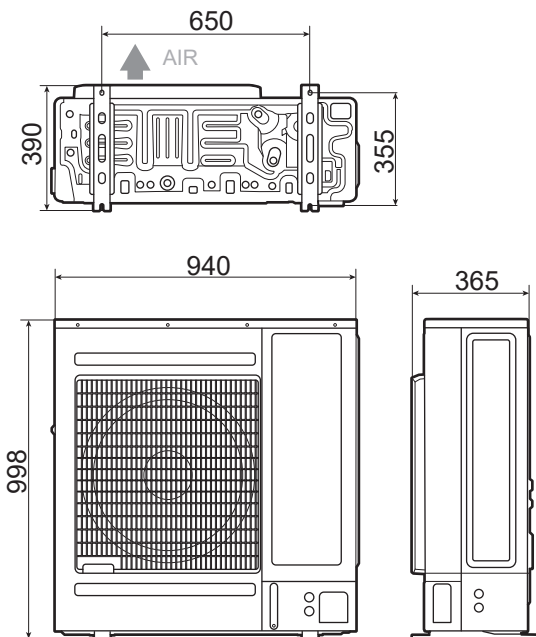
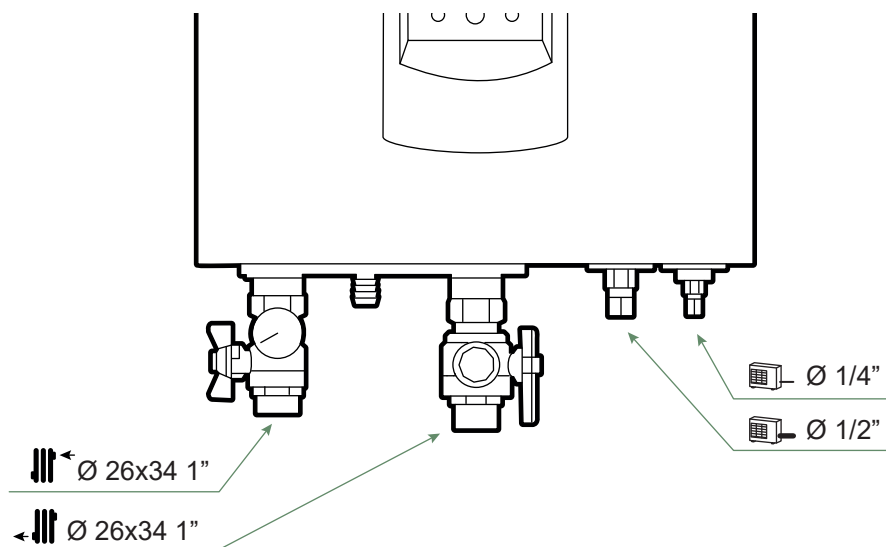
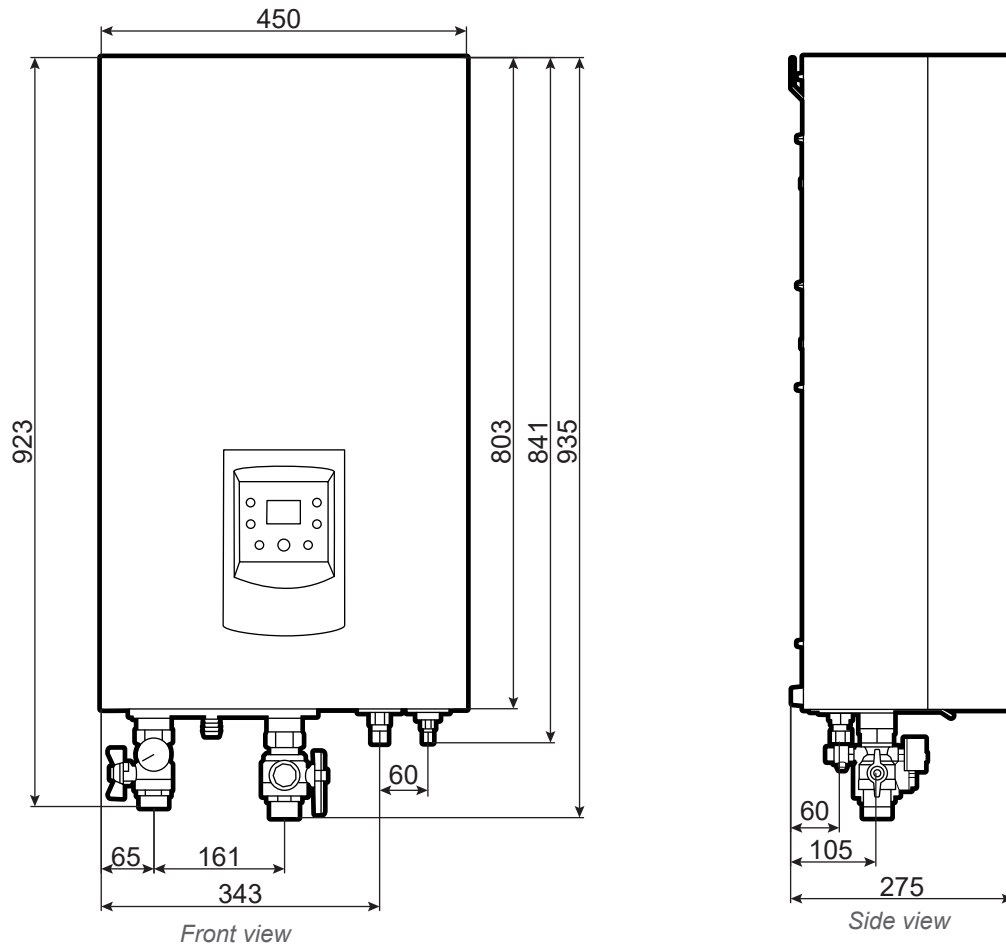

fig. 1 - Dimensions in mm

Hydraulic unit



Dimensions of the hydraulic unit, see § page 18

fig. 2 - Dimensions in mm

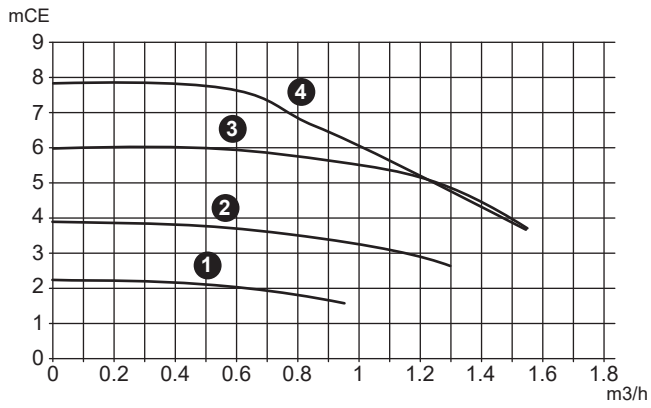
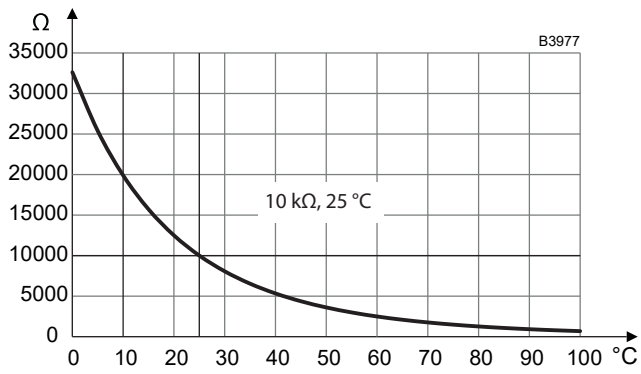

fig. 3 - Hydraulic pressures and flow rates available



HP return sensor.
 HP outgoing sensor.
 Outdoor sensor QAC2030 NTC.

fig. 4 - Ohmic value of the sensors (hydraulic unit - outdoor sensor)

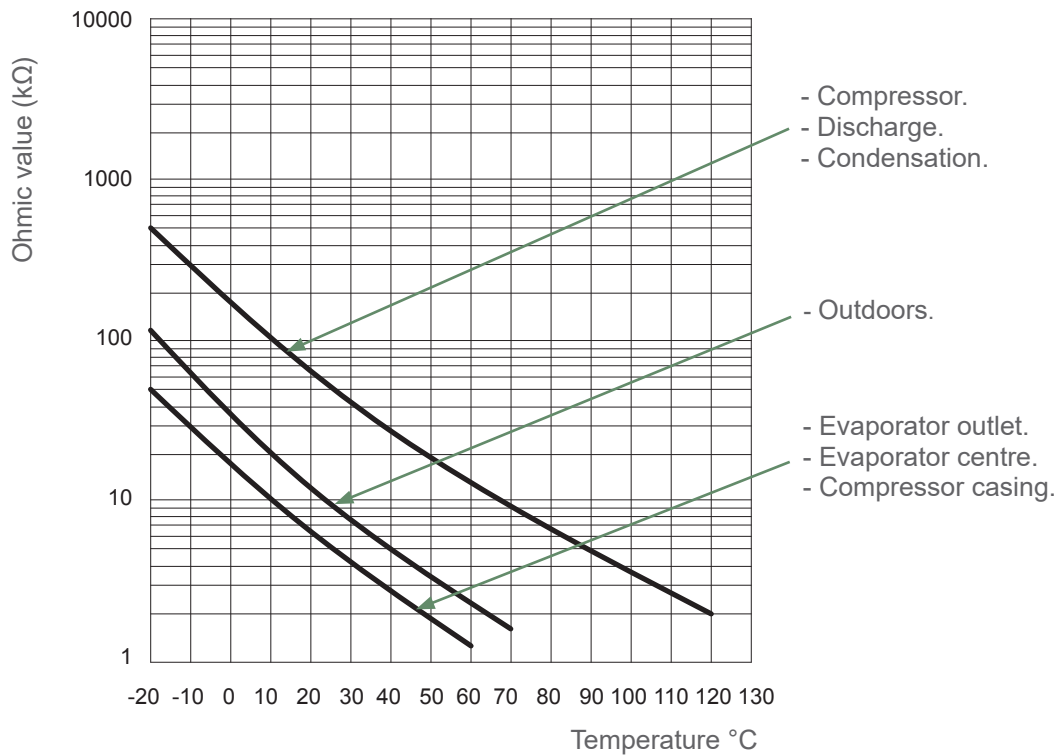
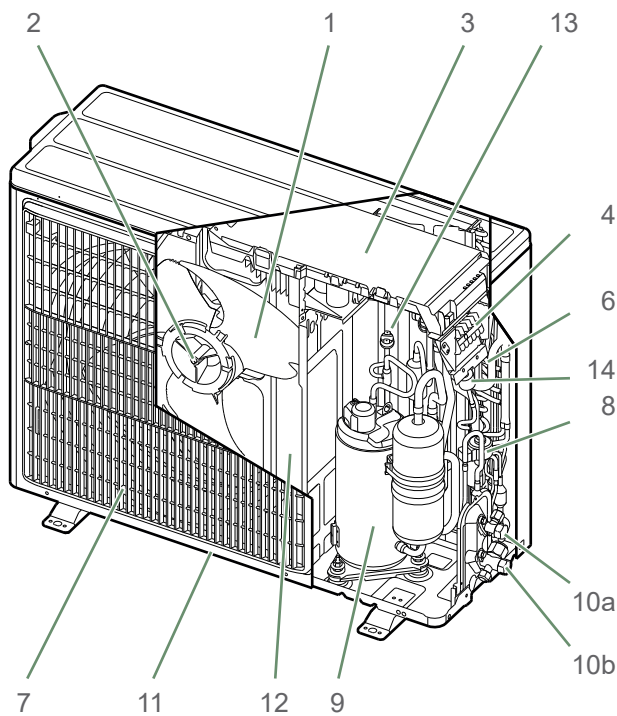

fig. 5 - Ohmic value of the sensors (outdoor unit)

► Description

■ Outdoor unit Model 4 & 6



■ Outdoor unit Model 8

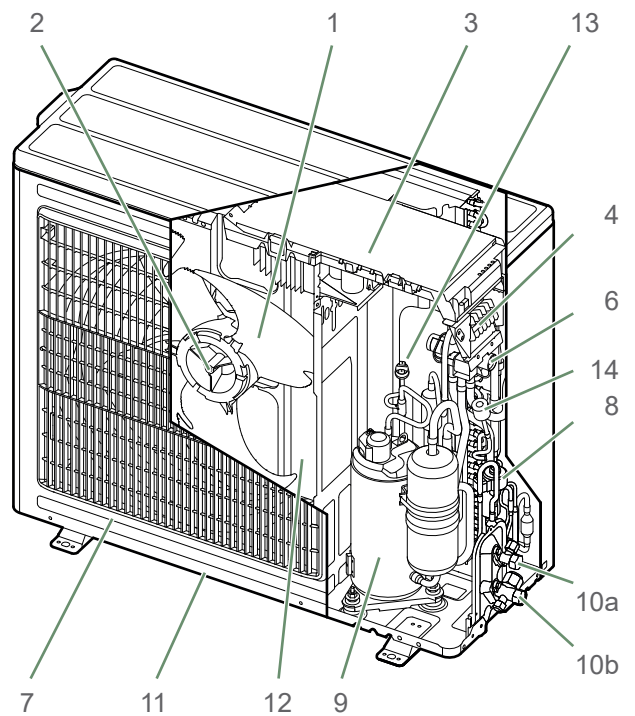

■ Outdoor unit Model 10

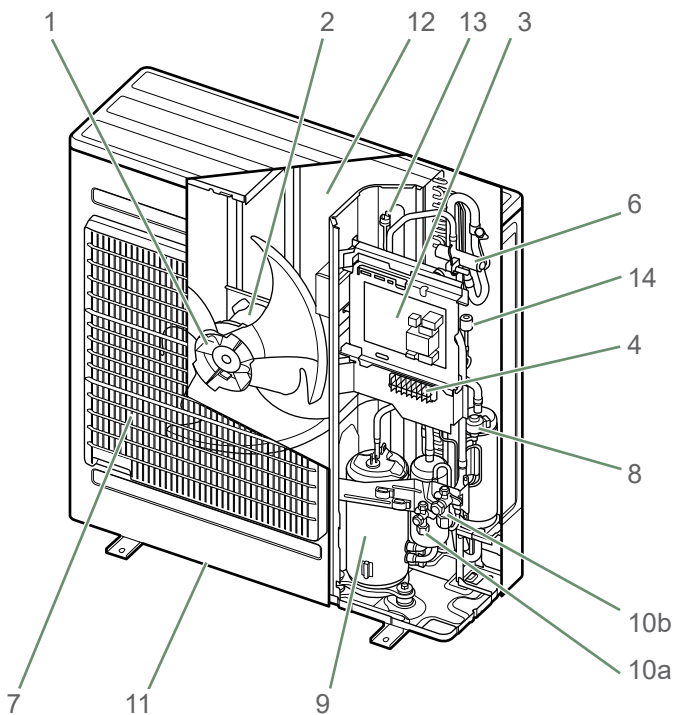

Key :

- | | |
|---|---|
| <ul style="list-style-type: none"> 1. High performance and low noise impeller. 2. Electrical motor with variable "Inverter" operation. 3. "Inverter" control unit. 4. Connection terminal blocks (power supply and interconnection). 6. 4-way valve. 7. Anti-corrosion treated bodywork. 8. Main circuit electronic expansion valve. | <ul style="list-style-type: none"> 9. Noise and thermally insulated "Inverter" compressor. 10. Refrigeration connection valves (flared connectors) with protective caps (a: liquid; b: gas). 11. Holding tank with condensate drain hole. 12. High-performance exchange surface evaporator; anti-corrosion treated hydrophilic aluminium fins and grooved copper tubes. 13. Pressure Switch. 14. Pressure sensor. |
|---|---|

fig. 6 - Components

Hydraulic unit

Key:

1. Electric box.
2. Controller / User interface (description, see [page 44](#)).
3. Circulation pump.
4. Initial heating flow.
5. Return heating flow.
6. Gas refrigeration connection.
7. Liquid refrigeration connection.
8. Safety valve.
9. Automatic air bleeder.
10. Expansion vessel.
11. Condenser (exchanger).
12. Electrical back-up.
13. Filter valve (supplied unassembled).
14. Valve (supplied unassembled) Pressure gauge / Bleed tap.
15. Flow meter.
16. HP outgoing sensor.
17. HP return sensor.
18. Reset button (overheating safety device).

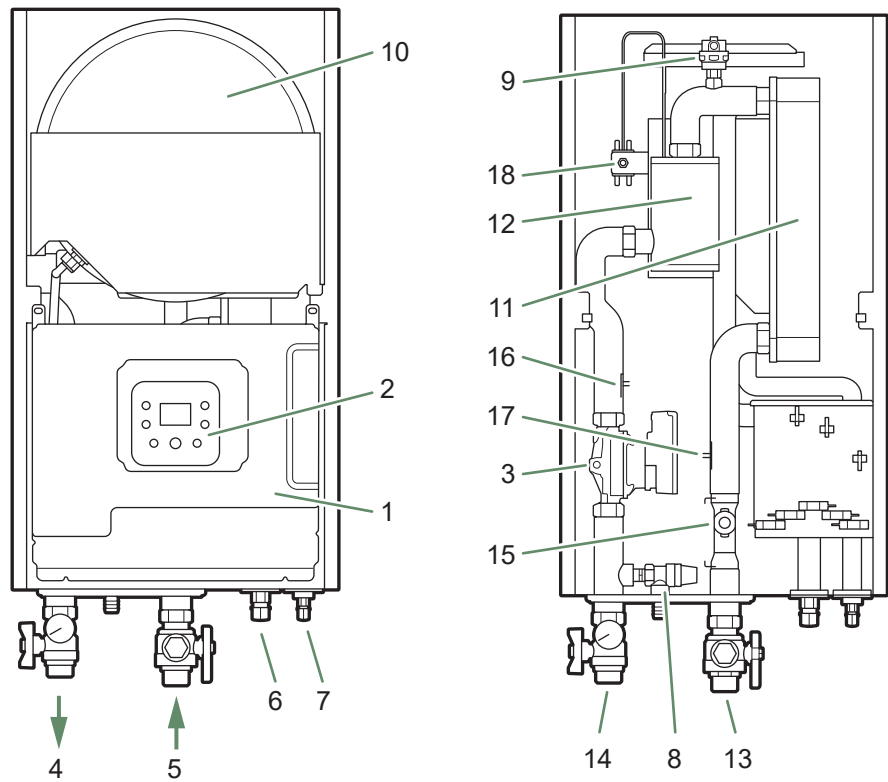

Front views

fig. 8 - Components

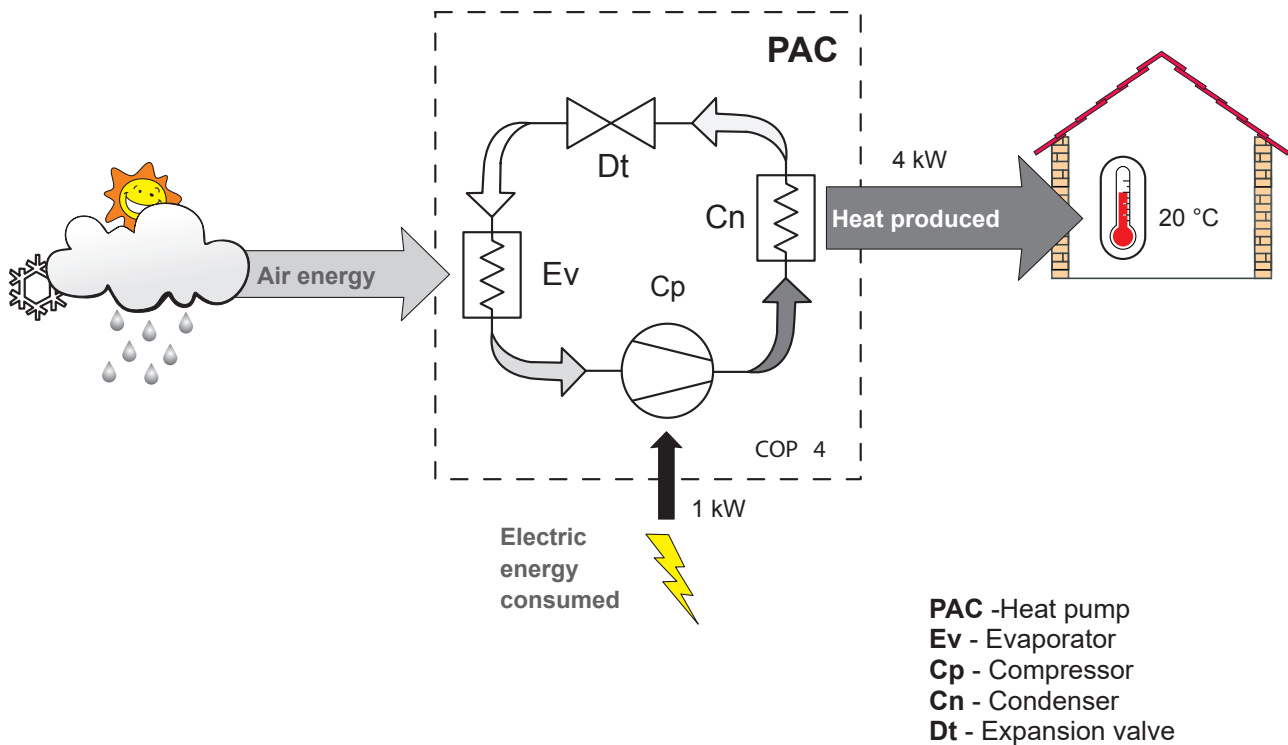

fig. 7 - Operating principle of a heat pump

► Operating principle

The heat pump transmits the energy contained in the surrounding air into the residence to be heated.

The heat pump consists of four main elements, in which a refrigerant (R32) circulates.

- In the evaporator (reference **12**, *fig. 6*): The energy is taken from the surrounding air and is transmitted to the refrigerant. Because it has a low boiling point, it changes from liquid state to vapour state, even in cold weather (down to -15 °C outdoor temperature).
- In the compressor (reference **9**, *fig. 6*): The vaporised refrigerant is brought to high pressure and takes on more calories.
- In the condenser (reference **23**, *fig. 6*): The energy in the refrigerant is transmitted to the heating circuit. The refrigerant returns to its liquid state.
- In the expansion valve (reference **8**, *fig. 6*): The liquefied refrigerant is brought back to low pressure and returns to its initial temperature and pressure.

The heat pump has a regulator that controls the indoor temperature based on the measurement of the outdoor temperature, known as weather-dependent control. The room thermostat (optional) corrects the weather-dependent setpoint.

The hydraulic unit is equipped with an electrical back-up system, which is designed to provide additional heat during the coldest periods.

• Regulation functions

- The initial temperature of the heating circuit is controlled by the weather-dependent setpoint.
- The power of the outdoor unit is modulated according to the need via the "inverter" compressor.
- Control of the electrical back-up.
 - ➔ Additional heating when the HP alone is insufficient.
 - ➔ Assist mode.
- Switching between summer/winter operation is automatic.
- Room thermostat*: The room thermostat corrects the weather-dependent setpoint.
- Domestic hot water*



• Protection functions

- Compressor protection via heating back-up (see *page 48*).
- Heat exchanger protection via heating back-up.
- Legionella cycle for domestic hot water.
- Minimum flow detection.
- Frost protection.
- Electrical back-up safety thermostat.



* When the heat pump is equipped with options and associated kits.

• Domestic hot water (DHW) operating principle (if the installation is equipped with a DHW tank).

Two domestic hot water (DHW) temperatures can be set:

- Comfort temperature ( ) and
- Reduced temperature ( **ECO**)

(see **user interface description page 44** or room thermostat):

The DHW programme ( **PROG**) is set by default to a comfort temperature () according to 2 pre-set phases (see "*DHW timer programme*", *page 52*) and a reduced temperature (**ECO**) for the rest of the day, which optimises electricity consumption while ensuring comfortable levels of hot water and heating.

The production of domestic hot water (DHW) is triggered when the temperature in the tank falls 7°C below the temperature setpoint.

The heat pump produces domestic hot water (DHW), which is then heated further, if required, by the electrical back-up system inside the tank.

To ensure that the DHW setpoint is reached, the electrical back-up system must be left on.

DHW production takes priority over heating; nevertheless the production of DHW is controlled by cycles that control the times assigned to the heating and the production of DHW in the event of simultaneous demand.

A DHW boost function is available (on the user interface: user level , setting "*95*", *page 55*). This DHW boost is used to heat the DHW to the comfort temperature at any time of day. The boost function is cancelled automatically when the demand for hot water has been met.

Legionella cycles can be programmed.

• Dynamic radiators or fan-coil heaters with integrated control system

Do not use a room thermostat in the zone concerned.

Layout

► Positioning the refrigerant connections

Manipulate the pipes and pass through slabs or walls with protective plugs in place or after brazing.

Keep the protective caps or brazed ends until commissioning the product.

The outdoor unit and the hydraulic unit must only be connected using copper connections (refrigerating grade), insulated separately.

Comply with with the pipe diameters.

Comply with the maximum and minimum distances between the hydraulic unit and the outdoor unit; the performance and service life guarantees depend on this.

The minimum length of the cooling connections is 3 m for correct operation.

The appliance's warranty will become void if it is applied with cooling connections that are shorter than 5 m (tolerance +/-10%).

If the refrigeration connections are exposed to weathering or UV rays and the insulation is not UV-resistant, protection must be provided.

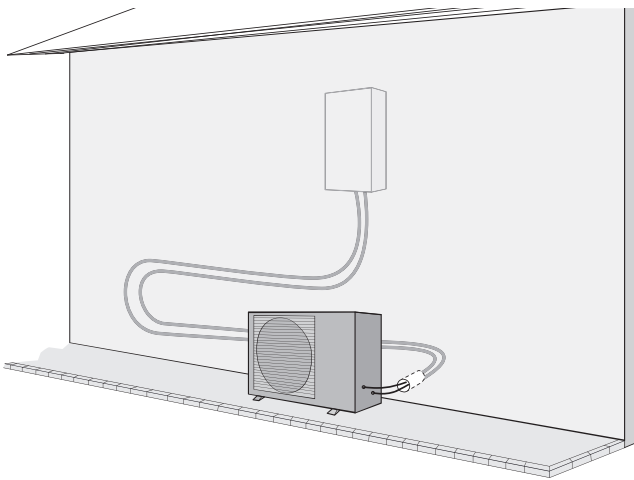

fig. 9 - Recommended example of refrigerant connections layout

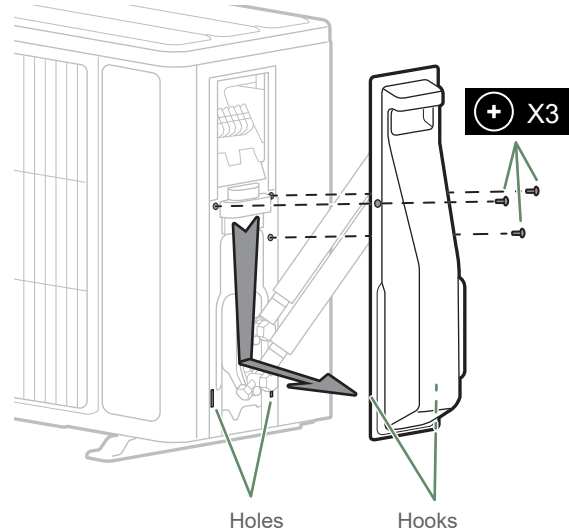

fig. 10 - Open the outdoor unit model 4, 6 & 8

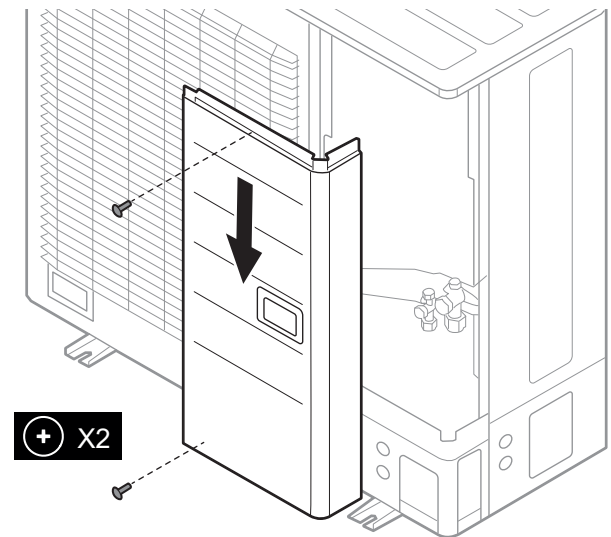

fig. 11 - Open the outdoor unit model 10

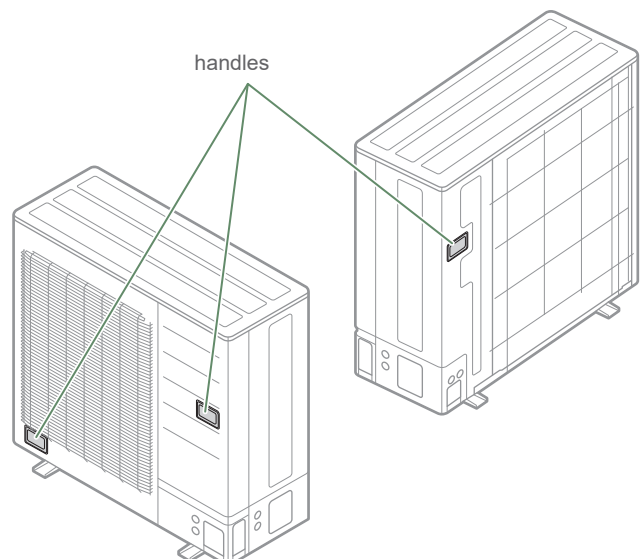

fig. 12 - Transport of the outdoor unit model 10

► Installing the outdoor unit

▼ Installation precautions



The outdoor unit must only be installed outside. If a shelter is required, it must have broad openings on all 4 sides and installation clearances must be observed.

- Choose the location of the appliance after discussion with the client.
- We recommend choosing a site that is sunny but sheltered from strong cold prevailing winds.
- The unit must be easily accessible for future installation and maintenance work (fig. 13 & fig. 14, page 16).
- Ensure that connections to the hydraulic unit can be made easily.
- The outdoor unit is able to withstand bad weather but avoid installing it in a position where it is likely to be exposed to significant dirt or flowing water (e.g. under a broken gutter).

- During normal operation, condensation is common. Ensure that the unit is installed in a well drained location (e.g. Gravel, sand). If installation is carried out in an area where the temperature stays below 0°C for long periods, check that the presence of ice does not present any danger. A drain pipe can be connected to the condensate drain tray (option) (fig. 15).

- Caution should be taken to ensure that there is no obstruction to air circulating through the outdoor unit (fig. 13 & fig. 14, page 16).

- Keep the outdoor unit away from heat sources and flammable products.

- Make sure that the unit does not disturb the surrounding area or inhabitants (noise level, draught, low temperature of the ejected air freezing the plants in its path).

■ Outdoor Unit, models 4, 6, 8

A ≥ 100 mm
B ≥ 200 mm
C ≥ 250 mm
D ≥ 300 mm
E ≥ 400 mm
F ≥ 500 mm

G ≥ 600 mm
H ≥ 1000 mm
J ≥ 1500 mm
K ≥ 2000 mm
L = 200 mm max
M = 300 mm max

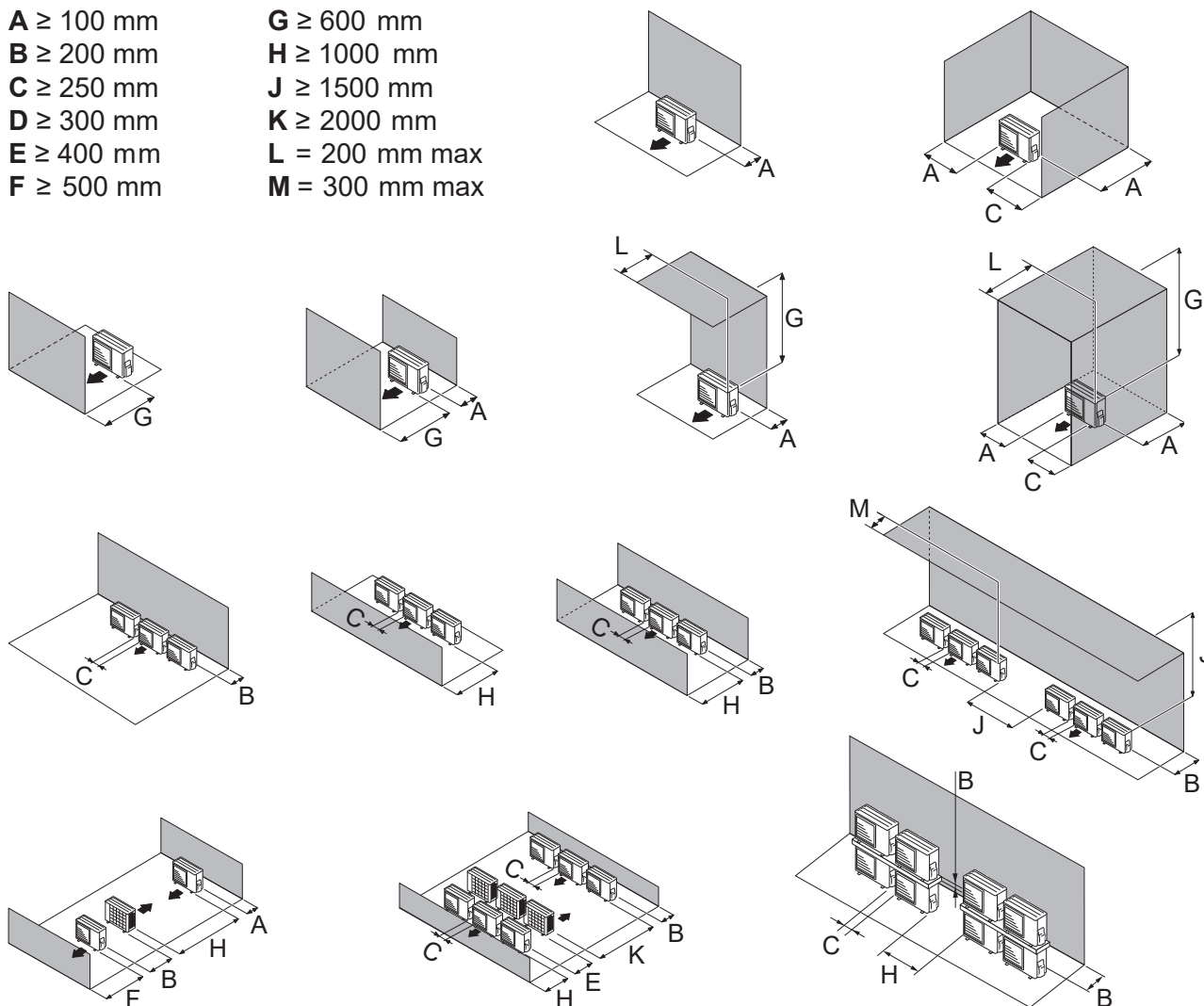

fig. 13 - Minimum installation clearances around the outdoor unit (model 4, 6 & 8)

■ Outdoor Unit, model 10

- | | |
|-------------------|-----------------------|
| A ≥ 100 mm | H ≥ 1000 mm |
| B ≥ 150 mm | J ≥ 1500 mm |
| C ≥ 200 mm | K ≥ 3000 mm |
| D ≥ 250 mm | L ≥ 3500 mm |
| E ≥ 300 mm | M = 300 mm max |
| F ≥ 500 mm | N = 500 mm max |
| G ≥ 600 mm | |

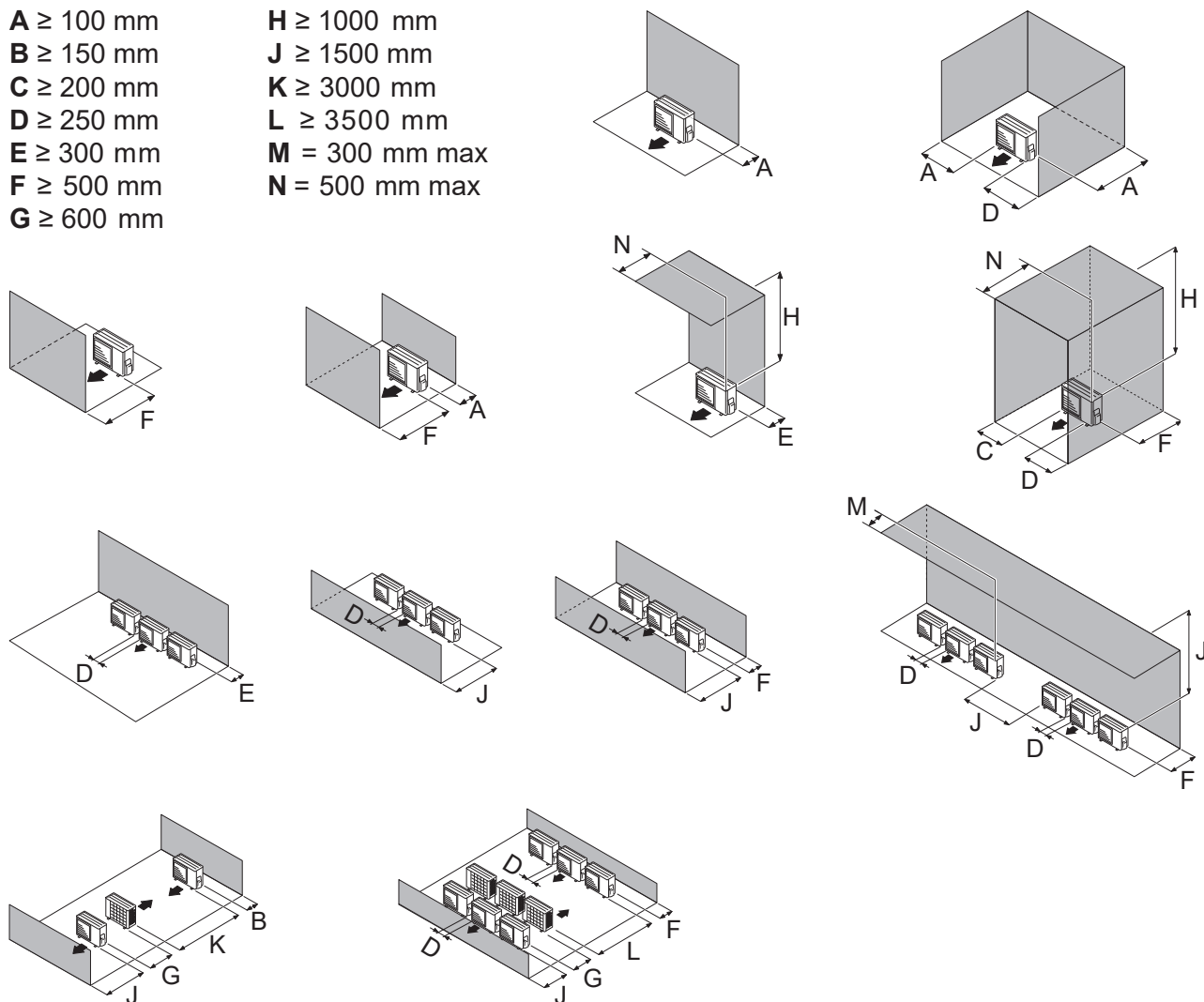

fig. 14 - Minimum installation clearances around the outdoor unit (model 10)

- The surface on which the appliance is installed must:
 - Be permeable (soil, gravel, etc.).
 - Be perfectly flat,
 - Support its weight easily.
 - Allow a solid fastening base,
 - Not transmit any vibration to the dwelling. Anti-vibration blocks are available as an option.
- The wall bracket cannot be used where it is likely to transmit vibrations. Installing the unit on the ground is preferred.

▼ Positioning Outdoor Unit

The outdoor unit must be raised at least 50 mm above ground level. In areas prone to snow, this height should be increased but should not exceed 1.5 m (fig. 15).

- Fasten the outdoor unit by means of screws and rubber tightening or toothed lock washers to prevent them from coming loose.

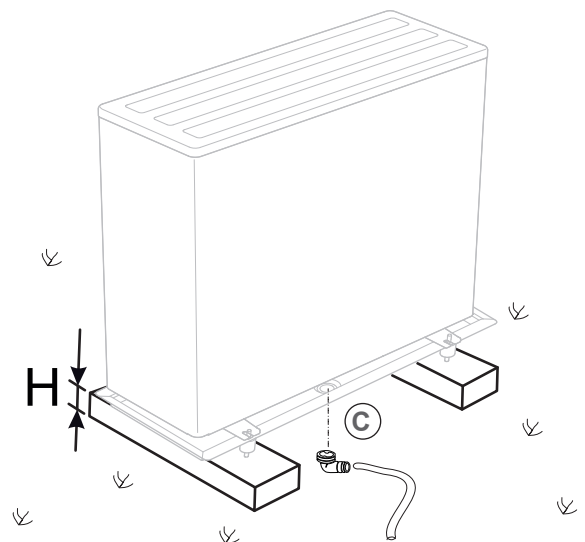

* In areas with heavy snowfall, (H) must be higher than the average snow layer



In areas with heavy snowfall, if the inlet and outlet of the outdoor unit are blocked with snow, heating may become difficult and a failure is likely to occur.

Construct a canopy or place the unit on a high stand (local configuration).

- Place the unit on a solid stand in order to minimise impacts and vibrations.
- Do not place the unit directly on the ground as this will cause problems.

▼ Condensate drain pipe



The outdoor unit can generate a large volume of water (called condensate).

If the use of a drain pipe is necessary (e.g., superposition of the outdoor units) :

- Install the condensate drain tray (optional) for models 4, 6 and 8 only. Use the elbow provided (C) and connect a 16 mm-diameter hose / pipe for draining the condensate.
- Use the stopper or stoppers provided (B) to block the opening of the condensate tank.

Allow for the condensate to flow away under the force of gravity (waste water, rain water, gravel bed).

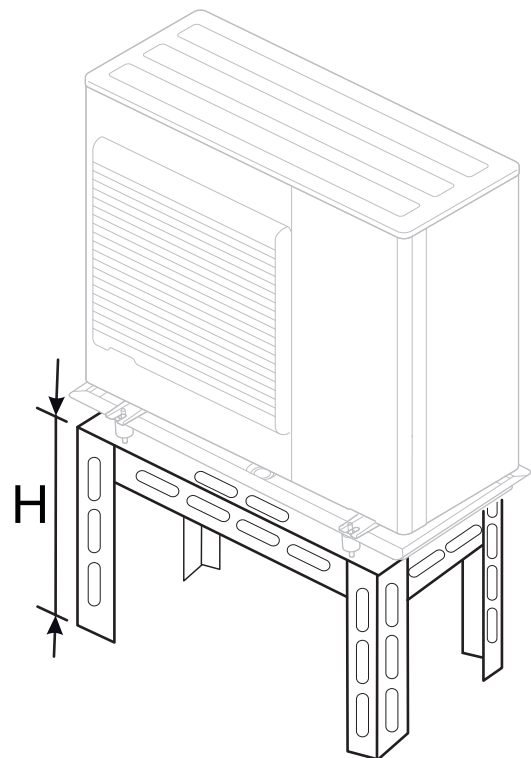

■ Only model 10

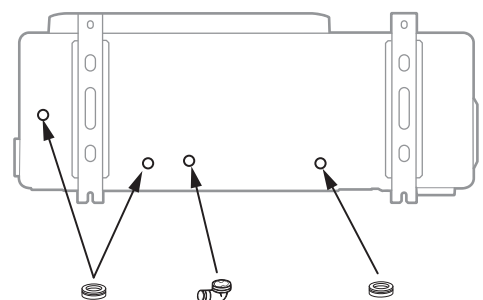

If installation is carried out in an area where the temperature stays below 0°C for long periods, equip the drain pipe with trace heating to avoid it icing up. Trace heating must heat not only the drain pipe but also the bottom of the appliance's condensate collection tank.

fig. 15 - Positioning the outdoor unit, discharging condensates

► Installation of the hydraulic unit

Heat sources such as :

- Open flame,
- High temperature surface >700°C (filament),
- >5 kVA unsealed contactor,

Avoid using sources of heat inside the room where the heat pump is installed. If this is not possible, see [page 22](#)



▼ Installation precautions

- Choose the location of the appliance after discussion with the client.
- The installation space should comply with current regulations.
- To facilitate maintenance and allow access to the various parts, we recommend that you provide sufficient space all the way around the hydraulic unit.

Other precautions

Be careful not to bring flammable gas near the heat pump during installation, in particular when brazing is required. The appliances are not fireproof and should not therefore be installed in an explosive environment.



- To avoid condensation inside the condenser, remove the refrigeration circuit caps **only when making the refrigeration connections**.
 - If the refrigeration connection is only performed at the end of the installation, make sure that the refrigeration circuit caps* remain in place and tight throughout the installation.
- * (Hydraulic unit side and outdoor unit side).
- After each maintenance operation on the refrigeration circuit and before the final connection, take care to put the caps back in position to avoid any pollution of the refrigeration circuit (sealing with adhesive is prohibited).

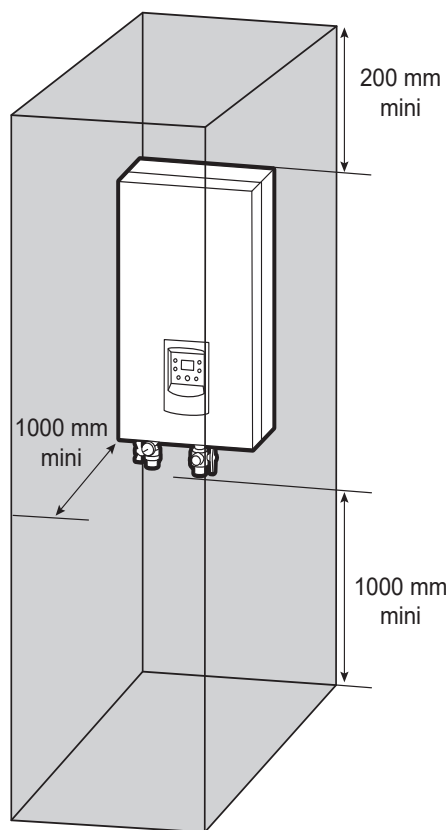

fig. 16 - Minimum installation clearances around the hydraulic unit

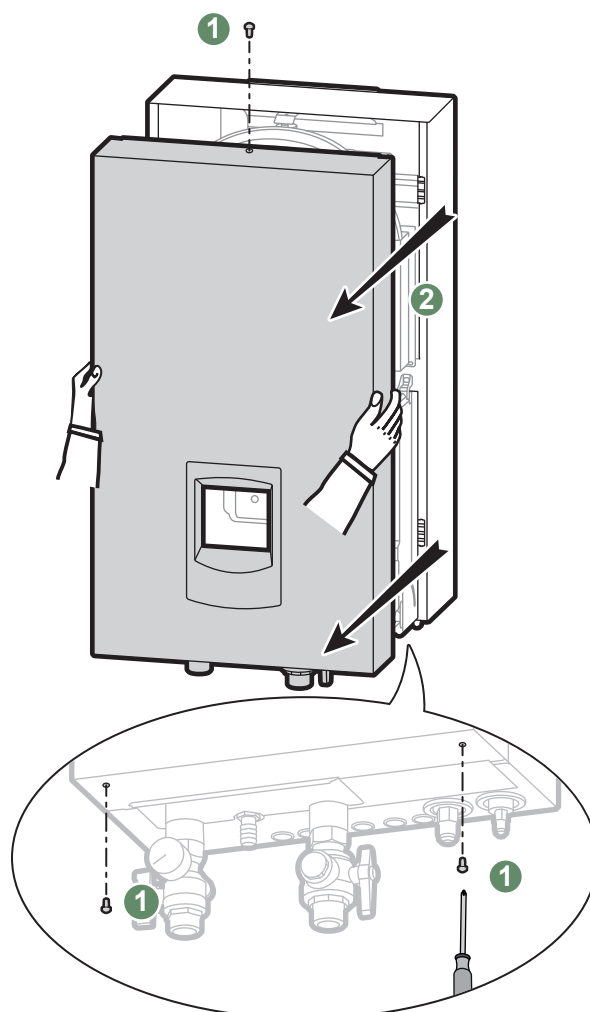

fig. 17 - Removing the front panel



A series of horizontal dotted lines spanning the width of the page, providing a guide for handwriting practice.

▼ Minimum room volume

In accordance with EN 378-1 -2017 standard (Refrigerating systems and heat pumps - Safety and environmental requirements), the system's hydraulic unit and all refrigeration connections passing through inhabited areas must comply with the minimum room volume requirements shown hereafter (voir *fig. 18*) :

The minimum volume of a room (in m³) is calculated using the formula: "fluid fill load" (in kg) / 0.3.

Alternatively, you must ensure that :

- The location has natural ventilation through another room where the combined volume of the two rooms is greater than "liquid fill load" (in kg) / 0.3kg/m³. Ventilation between the two rooms is ensured by openings of at least: see *fig. 19* and *fig. 20*.
- Or that the location is mechanically ventilated:
 - Minimum flow rate of 165m³/H;
 - Extraction at less than 0.20m from the floor.

Refrigeration connections Length			Model (kW)		
			4, 6	8	10
15 m	R32 gas charge	g	970	1020	1630
	min room volume	m ³	3.2	3.4	5.4
16 m	R32 gas charge	g	995	1045	1630
	min room volume	m ³	3.3	3.5	5.4
17 m	R32 gas charge	g	1020	1070	1630
	min room volume	m ³	3.4	3.6	5.4
20 m	R32 gas charge	g	1095	1145	1630
	min room volume	m ³	3.65	3.8	5.4
21 m	R32 gas charge	g	1120	1170	1650
	min room volume	m ³	3.73	3.9	5.5
22 m	R32 gas charge	g	1145	1195	1670
	min room volume	m ³	3.82	3.98	5.57
23 m	R32 gas charge	g	1170	1220	1690
	min room volume	m ³	3.9	4.1	5.6
25 m	R32 gas charge	g	1220	1270	1730
	min room volume	m ³	4.1	4.2	5.8
30 m	R32 gas charge	g	1345	1395	1830
	min room volume	m ³	4.5	4.7	6.1

fig. 18 - Minimum room volume

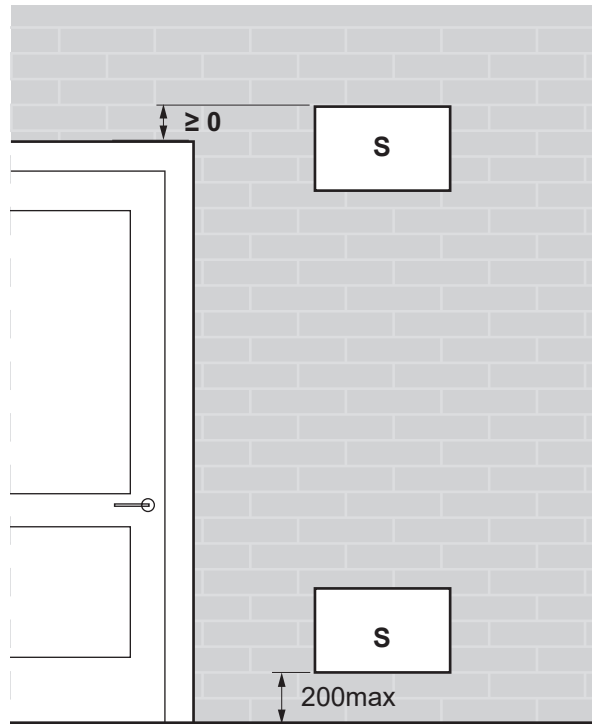

fig. 20 - Position of openings for ventilation

Room volume (m ³)	1.0	1.5	2.0	2.5	3.0	3.5	4.0	4.5	5.0	5.5	6.0	6.5					
Refrigerant Amount (g)	Minimal section (S) of the opening (cm²)																
970	500	350	250	200	200	No requirement											
1000	550	350	300	250	200												
1100	600	400	300	250	200								200				
1170	600	400	300	250	200								200				
1300	700	450	350	300	250								200	200			
1400	750	500	400	300	250								250	200	200		
1500	800	550	400	350	300								250	200	200	200	
1600	850	550	450	350	300								250	250	200	200	
1700	900	600	450	350	300								250	250	200	200	200
1800	950	650	500	400	350								300	250	250	200	200
1840	950	650	500	400	350	300	250	250	200	200	200						

fig. 19 - Section of the opening

▼ With Heat sources

Heat sources such as :

- Open flame,
- High temperature surface >700°C (filament),
- >5 kVA unsealed contactor,



In accordance with IEC 60-335-2-40 standard, the hydraulic module of the heat pump as well as all the refrigerant connections that cross the inhabited area must be installed in rooms respecting the minimum surface (fig. 22).

Depending on the total coolant load (heat pump + links + additional load):

if the minimal surface area (fig. 22) cannot be complied with, follow the instructions in fig. 24 to take into account the surface areas of adjoining rooms and the creation of ventilation points (see fig. 21 and fig. 23).

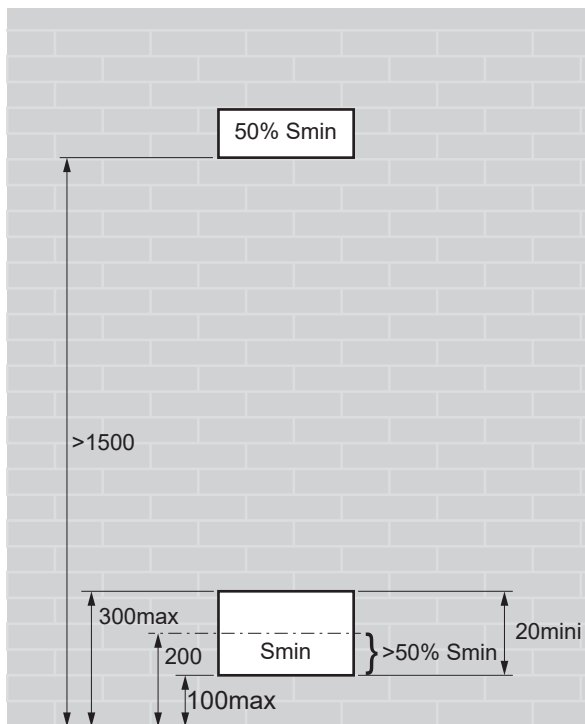

fig. 21 - Position of openings for ventilation

Refrigeration connections Length			Model (kW)		
			4, 6	8	10
15 m	R32 gas charge	g	970	1020	1630
	min room Surface	m ²	4.21	4.43	8.14
16 m	R32 gas charge	g	995	1045	1630
	min room Surface	m ²	4.32	4.54	8.14
17 m	R32 gas charge	g	1020	1070	1630
	min room Surface	m ²	4.43	4.65	8.14
20 m	R32 gas charge	g	1095	1145	1630
	min room Surface	m ²	4.76	4.97	8.14
21 m	R32 gas charge	g	1120	1170	1650
	min room Surface	m ²	4.86	5.08	8.43
22 m	R32 gas charge	g	1145	1195	1670
	min room Surface	m ²	4.97	5.19	8.54
23 m	R32 gas charge	g	1170	1220	1690
	min room Surface	m ²	5.08	5.30	8.75
25 m	R32 gas charge	g	1220	1270	1730
	min room Surface	m ²	5.30	5.52	9.17
30 m	R32 gas charge	g	1345	1395	1830
	min room Surface	m ²	5.84	6.06	10.26

fig. 22 - Minimum room surface

Surface of Room A (m ²)	0.8	1.0	1.5	2.0	2.5	3.0	3.5	4.0	4.5	5.0	5.5	6.0	6.5	7.0	7.5							
Refrigerant Amount (g)	Minimal section (Smin) of the low opening (cm ²)																					
970	246	232	196	160	124	88	51	15	No requirement													
1000	256	241	205	169	133	97	61	25														
1100	287	273	236	200	164	128	92	56								20						
1170	309	294	258	222	186	150	114	78								42	6					
1300	350	335	299	263	227	191	155	119								83	47	11				
1400	381	367	330	294	258	222	186	150								114	78	42	6			
1500	412	398	362	326	290	254	218	181								145	109	73	37	14		
1600	444	429	393	357	321	285	249	213								177	141	105	68	46	29	12
1700	475	461	424	388	352	316	280	244								208	172	136	100	77	61	45
1800	506	492	456	420	384	348	312	275								239	203	167	131	109	93	78
1840	519	504	468	432	396	360	324	288	252	216	180	144	122	106	91							

fig. 23 - Minimal section of the opening

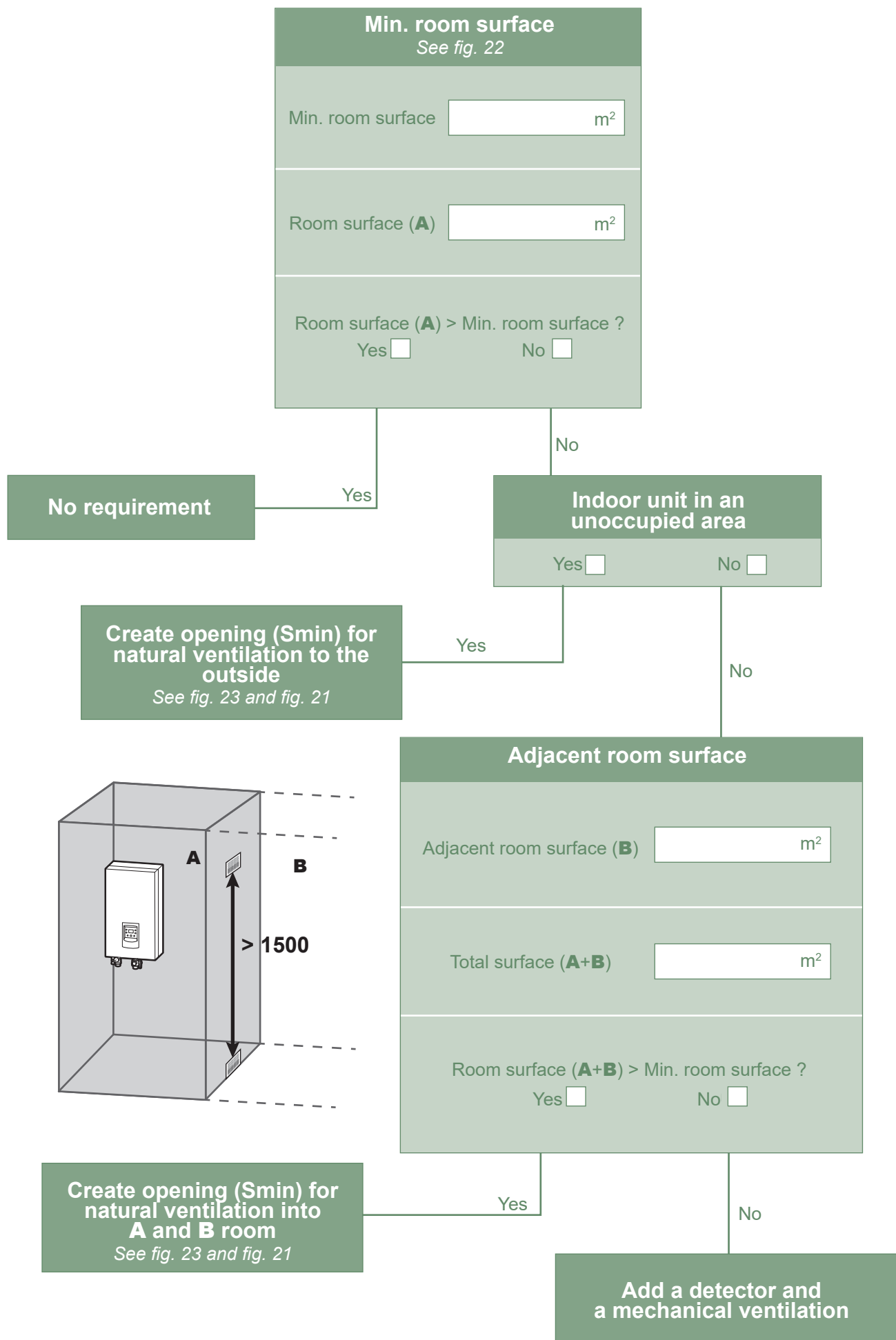

fig. 24 - Min. room surface

▼ Positioning the hydraulic unit

- Secure the support (4 screws and plugs) to a flat, sturdy wall (not a light-weight partition) ensuring that it is correctly levelled.
- Hook the appliance onto its support.

i Weight of hydraulic unit (full of water): 46 kg

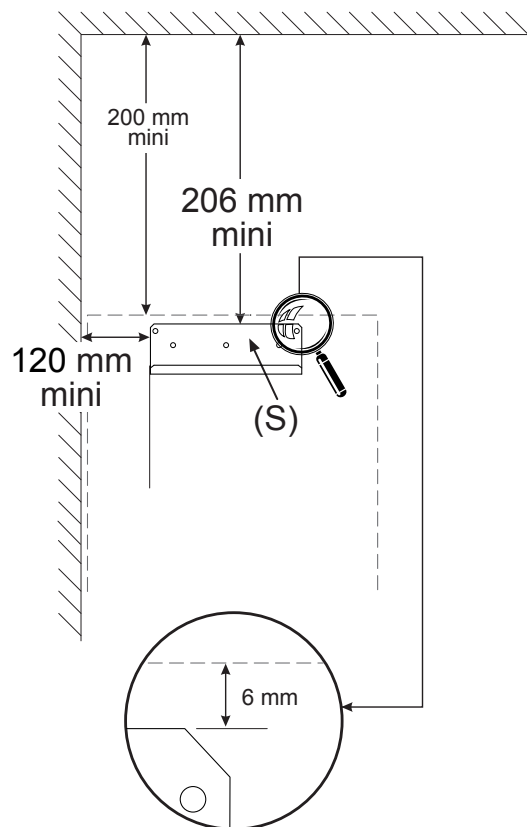

fig. 25 - Mounting bracket



A series of horizontal dotted lines spanning the width of the page, providing a guide for handwriting practice.

Refrigeration connections

This appliance uses refrigerant R32.

Comply with the legislation on handling of refrigerants.

► Rules and precautions



Connections must be made on the same day the installation is filled with gas (see para. "Filling the installation with gas", page 66).

• Minimum tools required

- Set of pressure gauges (*Manifold*) with hoses exclusively designed for HFCs (Hydrofluorocarbons).
- Vacuum gauge with isolation valves.
- Vacuum pump specifically for HFCs (using a standard vacuum pump is allowed if, and only if, it is fitted with a non-return valve on the suction side).
- Flaring tool, Pipe-cutter, Deburring tool, Spanners.
- Certified refrigerant gas leak detector (sensitivity 5g/ year).



Using tools that have been in contact with HCFCs (R22 for example) or CFCs is prohibited.

The manufacturer declines any liability with regard to the warranty if the above instructions are not observed.

• Flared connections



Lubricating with mineral oil (for R12, R22) is prohibited.

- Lubricate only with alkylbenzene oil. If alkylbenzene oil is not available, fit without lubrication.

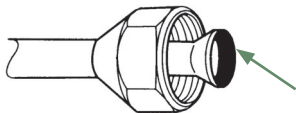

Coat the flared surface with alkylbenzene oil.
Do not use mineral oil.

• Brazing the refrigeration circuit (if necessary)

- Silver brazing (40% minimum recommended).
- Brazing only with dry nitrogen internal flux.

• Other remarks

- After each maintenance operation on the refrigeration circuit and before final connection, take care to put the caps back in position to avoid any pollution of the refrigeration circuit.
- To eliminate any filings getting into the pipes, use dry nitrogen to avoid introducing any humidity that may adversely affect the appliance's operation. In general, take every precaution to avoid humidity penetrating into the appliance.
- Proceed with the thermal insulation of the pipes / connections / refrigeration fittings in order to avoid any condensation. Use insulating sleeves resistant to temperatures above 90 ° C, at least 15mm thick if the humidity reaches 80% and at least 20mm if the humidity exceeds 80%. The thermal conductivity of the insulation is less than or equal to 0.040 W / mK. The insulation must be waterproof to resist the passage of steam during the defrost cycles.
Glass wool is prohibited.

► Shaping the refrigeration pipes

▼ Bending

The refrigeration pipes must be shaped only on a bending machine or with a bending spring in order to avoid any risk of crushing or breaking them.

Remove the insulation material from the section of pipe to be bent.

Do not bend copper to an angle greater than 90°.



The radius of curvature must be more than 2.5x \varnothing pipe.

Never bend pipes more than 3 times in the same place otherwise traces of fracturing may appear (hardening of the metal).

▼ Creating the flarings

- Cut the pipe to an appropriate length with a pipe-cutter without damaging it.
- Carefully deburr it, holding the pipe pointing downward to avoid introducing filings into the pipe.
- Remove the flared connection nut situated on the valve to be connected and slide the pipe into the nut.
- Proceed to flare it, letting the pipe protrude out of the flaring tool's tube.
- After flaring, check the state of the working radius (**L**). This must not present any scratches or signs of fracturing. Also check the dimension (**B**).

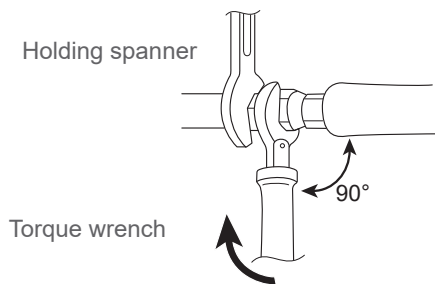

Designation	Tightening torque
Flared nut 6.35 mm (1/4")	16 to 18 Nm
Flared nut 9.52 mm (3/8")	32 to 42 Nm
Flared nut 12.7 mm (1/2")	49 to 61 Nm
Flared nut 15.88 mm (5/8")	63 to 75 Nm
Plug (A) 3/8", 1/4"	20 to 25 Nm
Plug (A) 1/2"	28 to 32 Nm
Plug (A) 5/8"	30 to 35 Nm
Plug (B) 3/8", 5/8", 1/2", 1/4"	12.5 to 16 Nm

Plug (A) and (B) : see fig. 58, page 67.

fig. 27 - Tightening torques

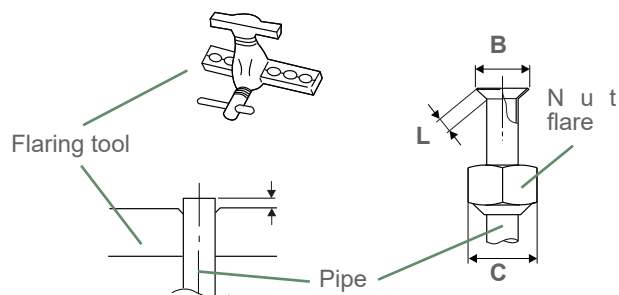

Pipe ø	Dimensions in mm		
	L	B 0/-0.4	C
6.35 (1/4")	1.8 to 2	9.1	17
9.52 (3/8")	2.5 to 2.7	13.2	22
12.7 (1/2")	2.6 to 2.9	16.6	26
15.88 (5/8")	2.9 to 3.1	19.7	29

fig. 26 - Flaring of the flare connections

HP models	4, 6		8		10	
	gas	liquid	gas	liquid	gas	liquid
Outdoor unit connections	1/2"	1/4"	1/2"	1/4"	5/8"	3/8"
Diameter:	(D1) 1/2"	(D2) 1/4"	(D1) 1/2"	(D2) 1/4"	(D1) 5/8"	(D2) 3/8"
Refrigeration connections	Minimum length (L)		3 m		3 m	
	Maximum length* (L)		15 m		20 m	
	Maximum length** (L)		30 m		30 m	
	Maximum Height Difference** (D)		20 m		20 m	
Male-female adapter (reduction)	-	-	-	-	(R1) 5/8" - 1/2"	(R2) 3/8" - 1/4"
Hydraulic unit connections	1/2"	1/4"	1/2"	1/4"	1/2"	1/4"

* : Without additional charge.

** : Including any additional filling (see page 30).

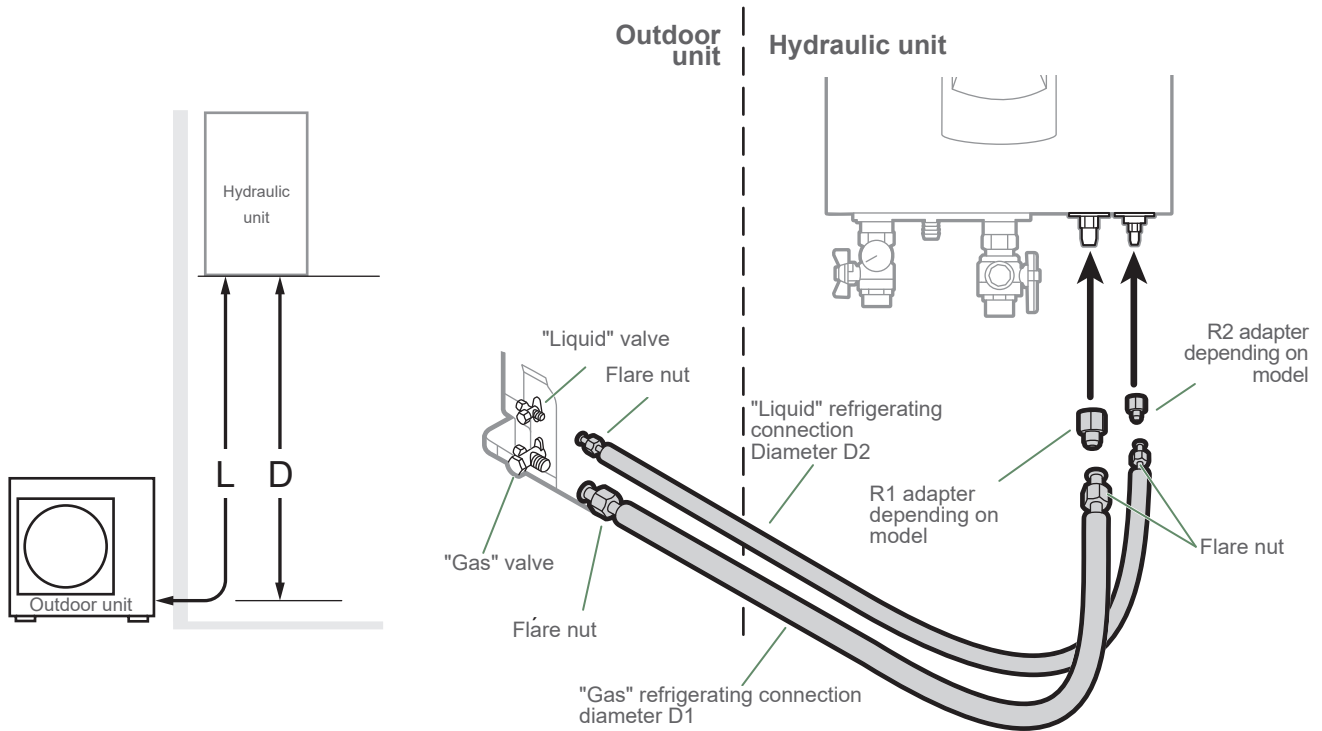

fig. 28 - Refrigerating link connection (accepted diameters and lengths)

► Checks and connection



The refrigeration circuit is very sensitive to dust and humidity: check that the area around the connection is clean and dry before removing the plugs protecting the refrigeration connectors.

Indicated blowing value: 6 bar for minimum 30 seconds for connection of 20 m.

Checking the gas connection (large diameter).

- 1 Connect the gas connection to the outdoor unit. Blow dry nitrogen into the gas connection and inspect its end:
 - If water or impurities emerge, use a brand new refrigeration connection.
- 2 Otherwise, proceed with flaring and connect the refrigeration connection to the outdoor unit immediately.

Checking the liquid connection (small diameter).

- 3 Connect the liquid connection to the hydraulic unit. Blow nitrogen into the **gas-condenser-liquid connection** system and inspect its end (outdoor unit side).
 - If water or impurities emerge, use a brand new refrigeration connection.
 - Otherwise, proceed with flaring and connect the refrigeration connection to the outdoor unit immediately.



Take particular care to position the tube opposite its connector so as not to risk damaging the threads. A properly aligned connector can be attached easily by hand without much force being required.

- Where necessary, connect an adapter (reducer) 3/8" - 1/4" or 5/8" - 1/2" (see *fig. 28*).
- Comply with the indicated tightening torques (*fig. 27, page 27*). If it is too tight, the fitting may break after a long period of time and cause a refrigerant leak.

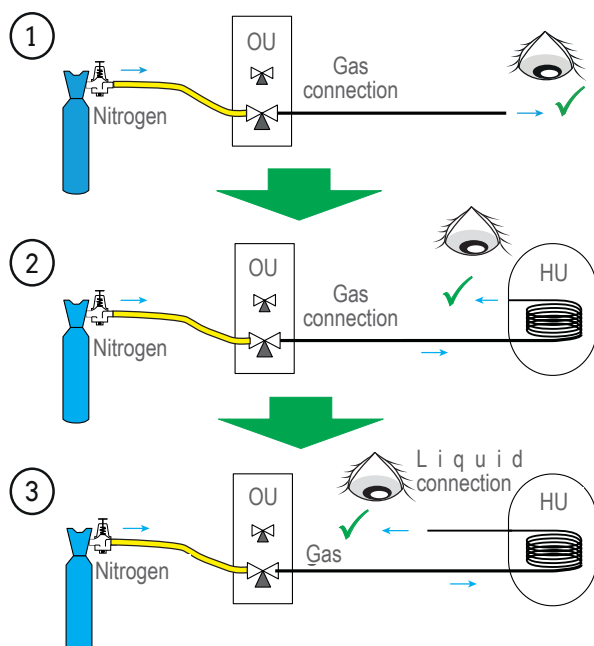

fig. 29 - Checking refrigeration connections

▼ Filling with gas

- See Appendices *page 66*



Indicate on the label present on the outdoor unit, the amount of gas (Factory + additional filling) see *fig. 30*.



If additional filling is required, do it before filling the hydraulic unit with gas. Refer to paragraph "Additional filling", *page 30*

- Remove the access plugs (A) (*fig. 58, page 67*) from the valve controls.
- First of all fully open the liquid valve (small) and then the gas valve (large) using an Allen (hex) key (anti-clockwise direction) without using excessive force against the stop.
- Quickly disconnect the hose from the *Manifold*.
- Refit the 2 original caps (be sure they are clean) and tighten them to the recommended tightening torque indicated in the table *fig. 27, page 27*. A seal is achieved in the caps only with metal to metal.
- The outdoor unit does not contain any additional refrigerant allowing the installation to be bled.
- Bleeding by flushing is strictly forbidden.

▼ Final sealing test

The sealing test must be carried out using a certified gas detector (sensitivity of 5g/year).

Once the refrigeration circuit has been gassed as described above, check that all the refrigeration connectors are gas-tight (4 connectors). If the flarings have been made correctly, there should be no leaks. If necessary, check the seal of the refrigeration valve caps.

If the event of a leak:

- Return the gas to the outdoor unit (pump down). The pressure should not drop below atmospheric pressure (0 relative bar read on the Manifold) so as not to contaminate the recovered gas with air or moisture.
- Redo the connection,
- Restart the commissioning procedure.

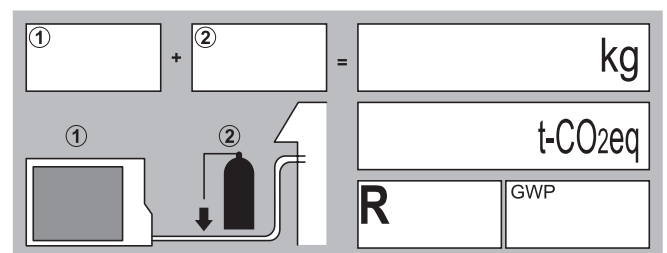

fig. 30 - Additional filling label

▼ Additional filling

The amount needed to fill the outdoor units corresponds to the maximum distances between the outdoor unit and the hydraulic unit as defined here [page 28](#). If the distances are greater, an additional amount of R32 is required. For each type of appliance, this additional amount depends on the distance between the outdoor unit and the hydraulic unit. Any additional filling with R32 must be carried out by an approved specialist.

Models 4, 6 and 8 (Outdoor unit WOYA060KLT, WOYA080KLT)

15m < Length of the connections ≤ 30m

(Length of the connections - 15m) x 25 g/m= g

Models / Factory fill	Length of the connections in m	16	17	X	29	30
Models 5, 6 / 970 g	Fill amount in g	995	1020	$970 + (X - 15) \times 25 = g$	1320	1345
Model 8 / 1020 g		1045	1070	$1020 + (X - 15) \times 25 = g$	1370	1395

Model 10 (Outdoor unit WOYA100KLT)

20m < Length of the connections ≤ 30m

(Length of the connections - 20m) x 20 g/m= g

Model... / Factory fill	Length of the connections in m	21	22	X	29	30
Model 10 / 1630 g	Fill amount in g	1650	1670	$1630 + (X - 20) \times 20 = g$	1810	1830

Filling must be carried out after creating a vacuum and before gassing the hydraulic unit, as follows:

- Disconnect the vacuum pump (yellow hose) and connect a bottle of R32 in its place **in the liquid extraction position**.
- Open the bottle's valve.
- Bleed the yellow hose by loosening it slightly on the Manifold side.
- Place the bottle on scales with a minimum accuracy of 10g. Note the weight.
- Carefully open the blue valve slightly and check the value shown on the scales.
- As soon as the value displayed has dropped by the value for the calculated additional fill amount, close the bottle and disconnect it.
- Quickly disconnect the hose connected to the appliance.
- Proceed to fill the hydraulic unit with gas.



Only use R32 !

Only use tools suitable for R32 (set of pressure gauges).

Always fill in the liquid phase.

Never exceed the maximum length or difference in level.

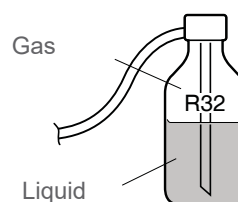

fig. 31 - Gas bottle R32

► Collecting refrigerant in the outdoor unit



Before performing any maintenance, make sure that all power supplies have been cut off.

Stored energy: after cutting off the power supplies, wait for 10 minutes before accessing the internal parts of the equipment.



Perform the following procedures to collect the refrigerant. Ensure that the pressure gauge kit (*Manifold*) has been previously installed.

- **1-** Power off the appliance and its peripherals (hydraulic unit, outdoor unit, back-up system(s)).
- **2-** Remove the front panel. Open the power control box. Switch the **DIP SW1** of the interface board to **ON**.
- **3-** Power ON the appliance and its peripherals (the green and red LEDs on the board start flashing; 1 sec. ON / 1 sec. OFF repeated) => The pump starts up. The outdoor unit starts in the cold mode for approximately 3 minutes after it is switched on.
- **4- Immediately after the outdoor unit starts:** close the liquid valve on the outdoor unit.
- **5-** Gradually close the gas valve on the outdoor unit **so that it is closed when the relative pressure drops below 0.02 bar** as read at the *Manifold* (about 1 or 2 minutes after closing the liquid valve), while the outdoor unit keeps running.
- **6-** Cut off the main power supply.
- **7-** The refrigerant collecting operation is complete.

Note:

- When the heat pump is operating, the pump down operation may not be activated, even if the **DIP SW 1** switch is set to **ON**.
- Do not forget to return the **DIP SW 1** switch to **OFF** after the pump down operation.
- If the pump down operation fails, try the procedure again by turning off the machine and opening the "gas" and "liquid" valves. After 2 to 3 minutes repeat the pump down operation.

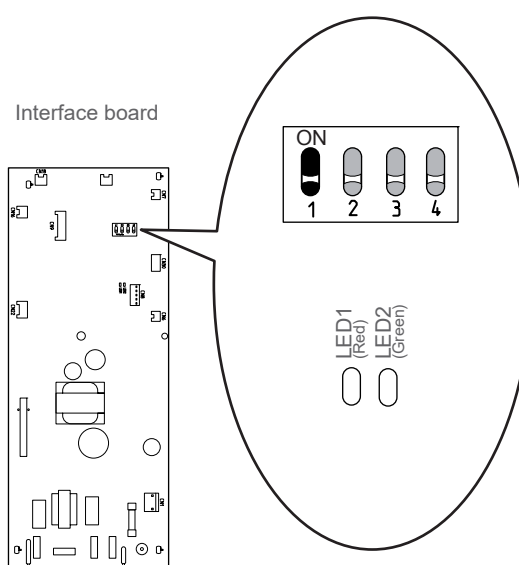

fig. 32 - Location of DIP switches and LEDs on the hydraulic unit interface board

Hydraulic connections

i See "Overall hydraulic layout", page 68

► Rinsing the installation

Before connecting the hydraulic unit to the installation, **rinse the heating system correctly** to eliminate the particles that could compromise the correct operation of the appliance. Provide a sufficiently large decanting pot with a drain on the return line from the heat pump and at the lowest point in the system in order to collect and remove the impurities.

Do not use solvents or aromatic hydrocarbons (petrol, paraffin, etc.).

Add an alkaline product to the water and a dispersant.

Rinse the installation several times before final filling.

► Connections

The heating circulating pump is built into the hydraulic unit.

The diameter of the pipe between the hydraulic unit and the heating manifold must be at least equal to 1 inch (26x34 mm). Tightening torque: 15 to 35 Nm.

• Water volume:

To maintain a comfortable level for the user, please comply with the minimum water volume per circuit (see table *page 7*).

Circuit equipped with dynamic radiators: a buffer must be installed and the minimum volume must comply with the specifications (*page 7*).

• Flow requirements:

- Calculate the diameter of the pipes according to the flow rates and the lengths of the hydraulic circuits.

The appliance will operate correctly if the flow range complies with the specifications (see table *page 7*). For this purpose, the HP is equipped with a flow meter that ensures a sufficient minimum flow in the heat exchanger. If flow is insufficient, the appliance will show a safety error.

For an installation with thermostat valves (floor heating system or radiator), a differential (bypass) valve must be installed or a valve-free hydraulic loop must be maintained far enough away from the HP to guarantee a minimum flow rate (*page 7*).

- Connect the pipe of the central heating to the hydraulic unit respecting the direction of flow.

- Install the valve filter on the heating return circuit in the manner suggested (ref. **VF**, *fig. 33*).

- Install the "pressure gauge" valve on the heating outgoing circuit in the manner suggested (ref. **V-M**).

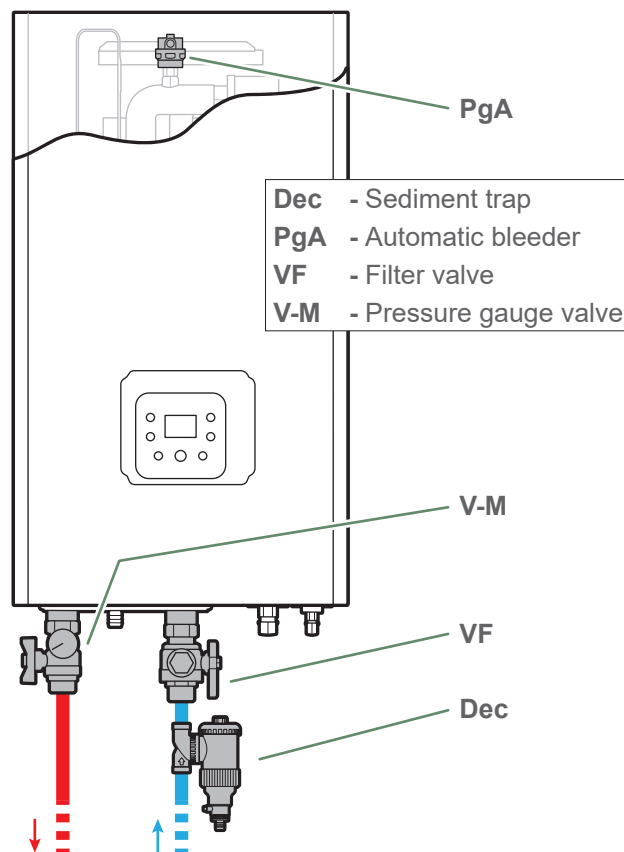

fig. 33 - Sediment trap (optional) on the heating return flow

We strongly recommend installing the sediment trap (optional) on the heating return circuit to collect and remove the impurities (ref. Dec).

- Use union connectors to facilitate removing the hydraulic unit.

- Prioritise connector hoses to avoid transmitting noise and vibrations to the building.

- Connect the drains from the drain valve and the safety valve to the main sewer system.

Verify the correct functioning of the expansion system. Control the vessel pressure (precharge 1 bar) and the safety valve setting.

▼ Connecting to an underfloor heating circuit

fig. 34

To ensure that the installation operates correctly on a floor heating system equipped with thermostat valves, provide a bypass (**A**) or an open loop (**B**) to guarantee the minimum flow rate required (see "*Specifications*", *page 7*).

In the event of non-compliance with the minimum flow rate, the HP shuts down (error 131 - see "*Hydraulic unit errors*", *page 58*).

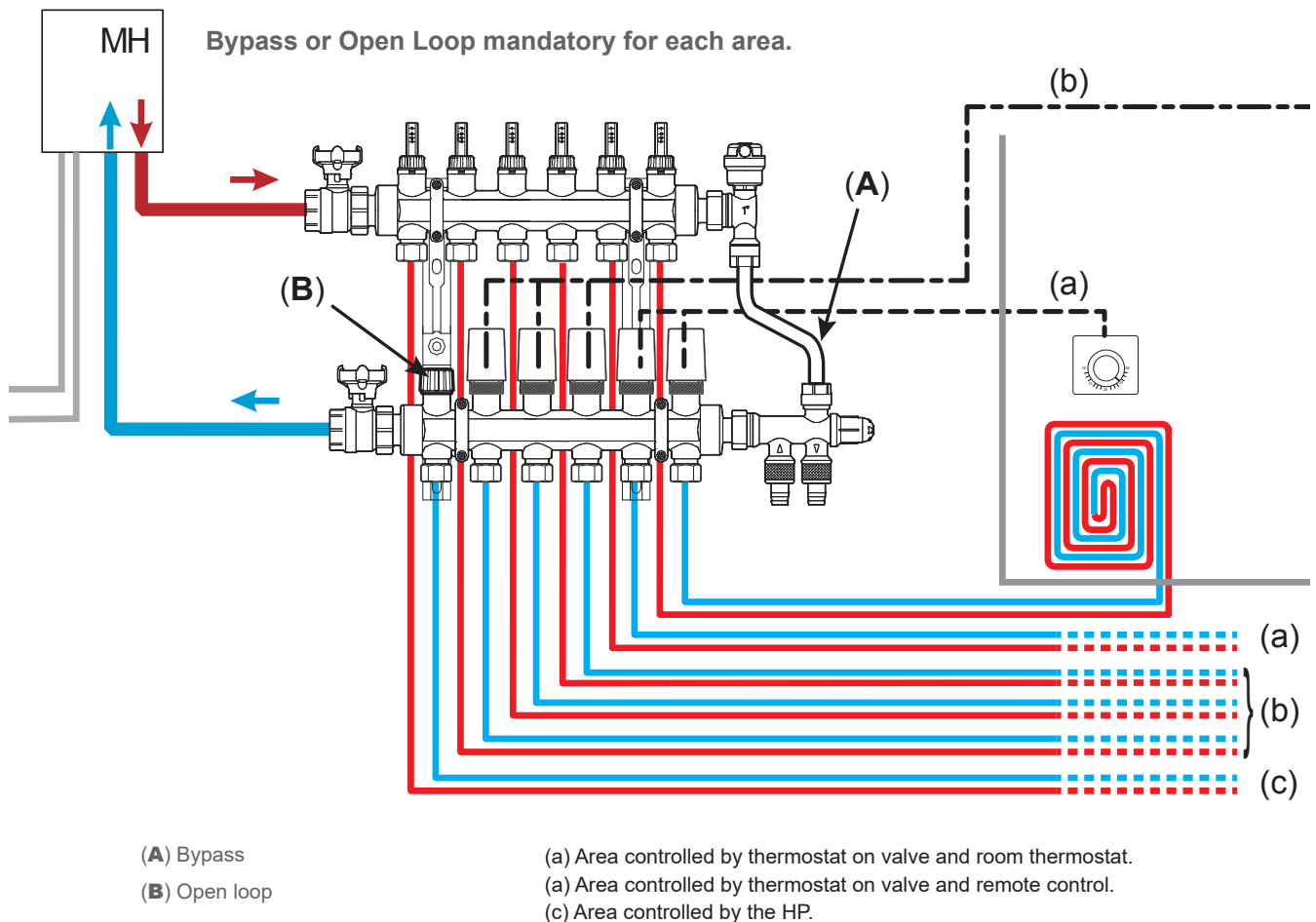

fig. 34 - Connecting the floor heating system

▼ Connecting to a dynamic radiator or fan-coil heater circuit

A buffer must be installed on the dynamic radiator return circuit (comply with the **minimum circulating water volume** (see table *page 7*). Also refer to "Overall hydraulic layout", *page 68 to page 70*).

Circuit...		
...combined (HC2)	...direct (HC1)	
UFH-R	DynR or FC	Buffer on HC1 return
DynR or FC	Radiators	Buffer on return of 2 circuits
DynR or FC	DynR or FC	

► Filling and draining the installation

Check the attachment of the pipes, that the connectors are tight and that the hydraulic unit is stable.

Check the water flow direction and that all of the valves are open.

Fill the installation.

Do not operate the circulating pump while filling. Open all the drain valves in the installation to remove the air contained in the pipes.

Close the drains and add water until the pressure of the hydraulic circuit reaches 1.5 bar.

Check that the hydraulic circuit is drained correctly.

Check there is not a leak.

After the "Commissioning" stage (see *page 48*), once the machine has started, purge the hydraulic unit again.

Precise filling pressure is determined by the manometric head of the installation.

Electrical connections



Before performing any maintenance, make sure that all power supplies have been cut off.

Electrical installation must be performed in accordance with current regulations.



The electrical diagram of the hydraulic unit is detailed in *page 72*.

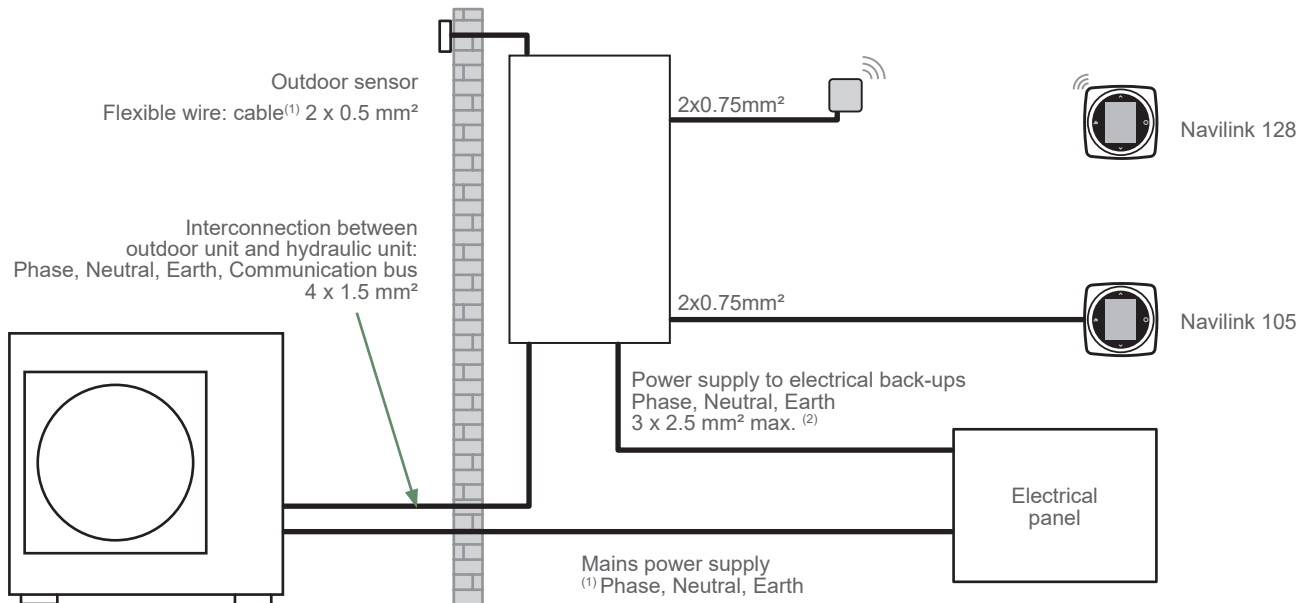

fig. 35 - Overall layout of the electrical connections for a single installation (1 heating circuit)

► Electrical power connections (LV)

▼ Cable section and protection rating

The cable sections are given for information purposes only and do not exempt the installer from checking that these sections correspond to the requirements and comply with the prevailing standards (also take into account the connection length).

• Power supply to outdoor unit

<i>Heat Pump (HP)</i>		<i>Electricity supply 230 V - 50 Hz</i>	
<i>Model</i>	<i>Max. power consumption</i>	<i>Connection cable (live, neutral, earth)</i>	<i>Circuit breaker C curve</i>
4 & 6	3260 W	3 G 1.5 mm ²	16 A
8	4510 W	3 G 2.5 mm ²	20 A
10	4760 W	3 G 4 mm ² or 3 G 6 mm ²	32A

• Interconnection between the outdoor unit and the hydraulic unit

The hydraulic unit is powered by the outdoor unit by means of a 4 G 1.5 mm² cable (live, neutral, earth, communication bus).

• Power supply to the electrical back-ups:

<i>Heat pump</i>	<i>Electrical back-ups</i>		<i>Power supply to the electrical back-ups</i>	
<i>Model</i>	<i>Power</i>	<i>Nominal current</i>	<i>Cable (phase, neutral, earth)</i>	<i>Curve C circuit breaker size</i>
4, 6, 8 and 10	3000 W	13 A	3 x 1.5 mm ² ⁽²⁾	16 A

⁽²⁾Note: The cable used to connect the electrical back-up must not exceed 3 x 2.5 mm² (the spring terminal cannot receive wires with a diameter exceeding 2.5 mm²).

▼ Outdoor unit

Access to connection terminals:

■ Models 4, 6 and 8

- Remove the cowl.

• Model 10

- Remove the front panel.



Avoid contact between cables and refrigeration valves / connections.



Use cable clamps to prevent any power cables from being disconnected accidentally.

Fill in the space where the cables enter the outdoor unit with the insulating plate.

■ Models 4, 6 and 8

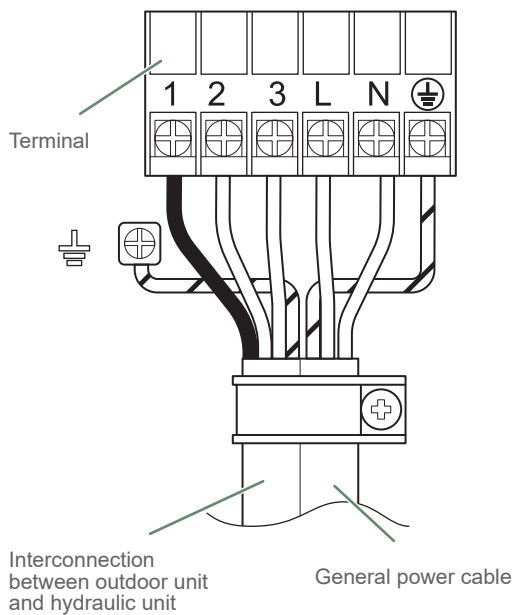

■ Models 4, 6 and 8

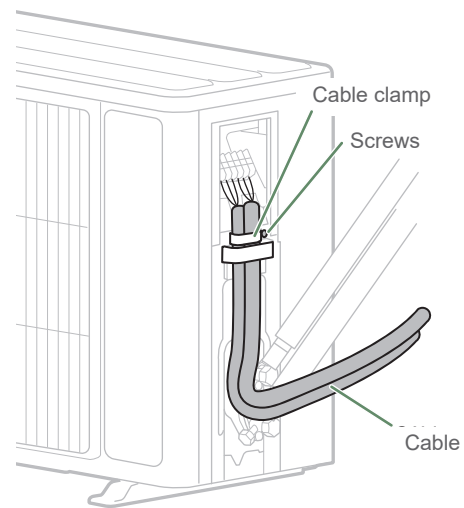

■ Model 10

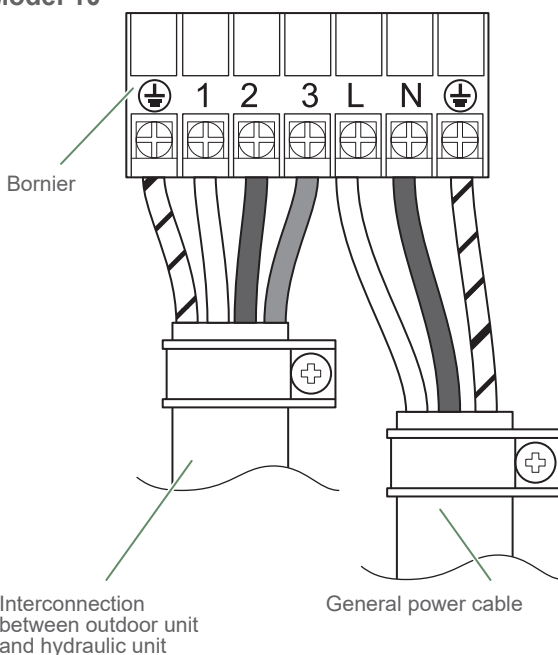

■ Model 10

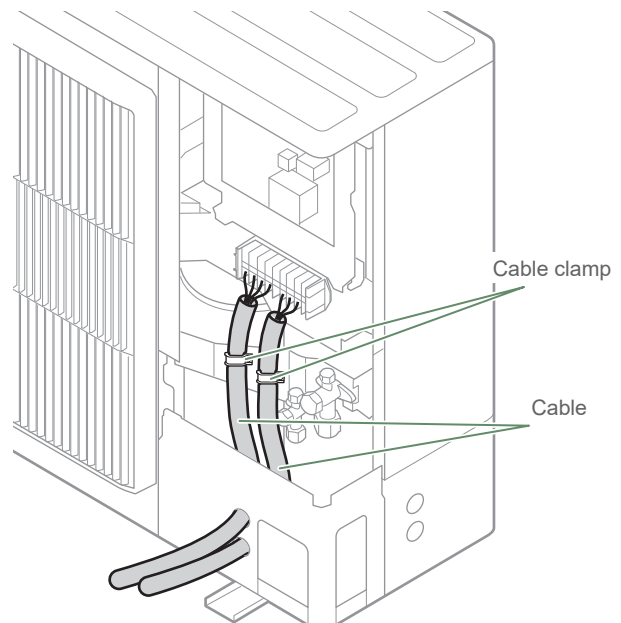

fig. 36 - Connections to outdoor unit's terminal block

fig. 37 - Access to outdoor unit's terminal block

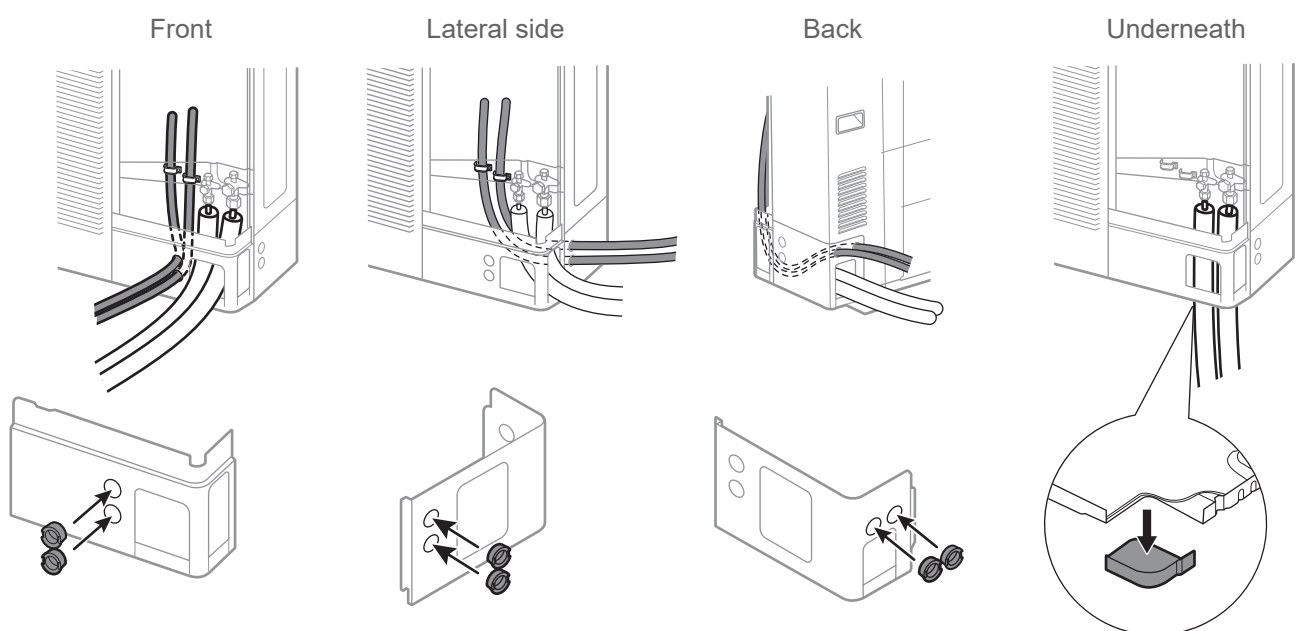

fig. 38 - Location of electrical cables and refrigeration connections to outdoor unit (Model 10)

▼ Hydraulic unit

To access the connector terminals:

- Remove the front panel (3 screws)
- Rotate and open the electric box (2 + 3 screws).

- Make the connections according to the diagram (fig. 42).

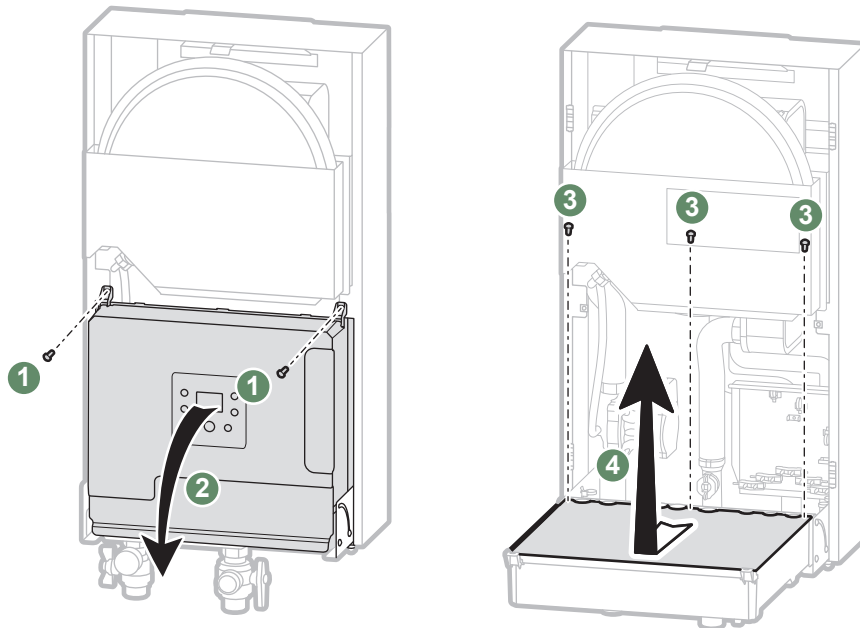
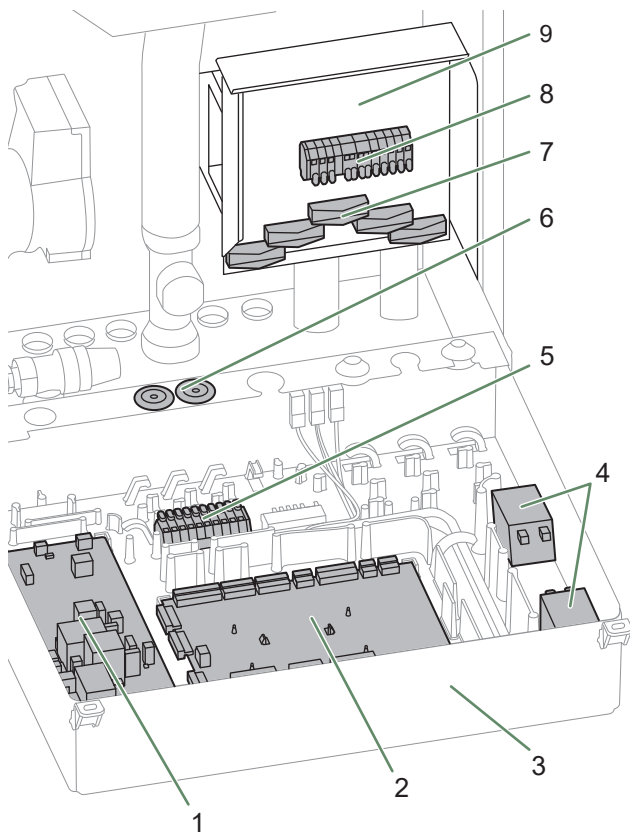

fig. 39 - Accessing the electric box



Key:

1. Interface board.
2. HP Controller board.
3. Electric box.
4. Relays.
5. Sensor terminal blocks (SELV).
6. Cable grommet (Sensors)
Flexible wire mandatory.
7. Cable clamp (power).
8. Power terminal blocks (LV).
9. Box (terminals).

fig. 40 - Electric box: Description

- Do not place the sensor lines and the sector supply lines in parallel in order to avoid interferences due to voltage points in the sector supply.

- Do not lay the electrical cables on piping (water and refrigerant pipes).

- Ensure that all of the electrical cables are housed in the spaces provided (fig. 41).

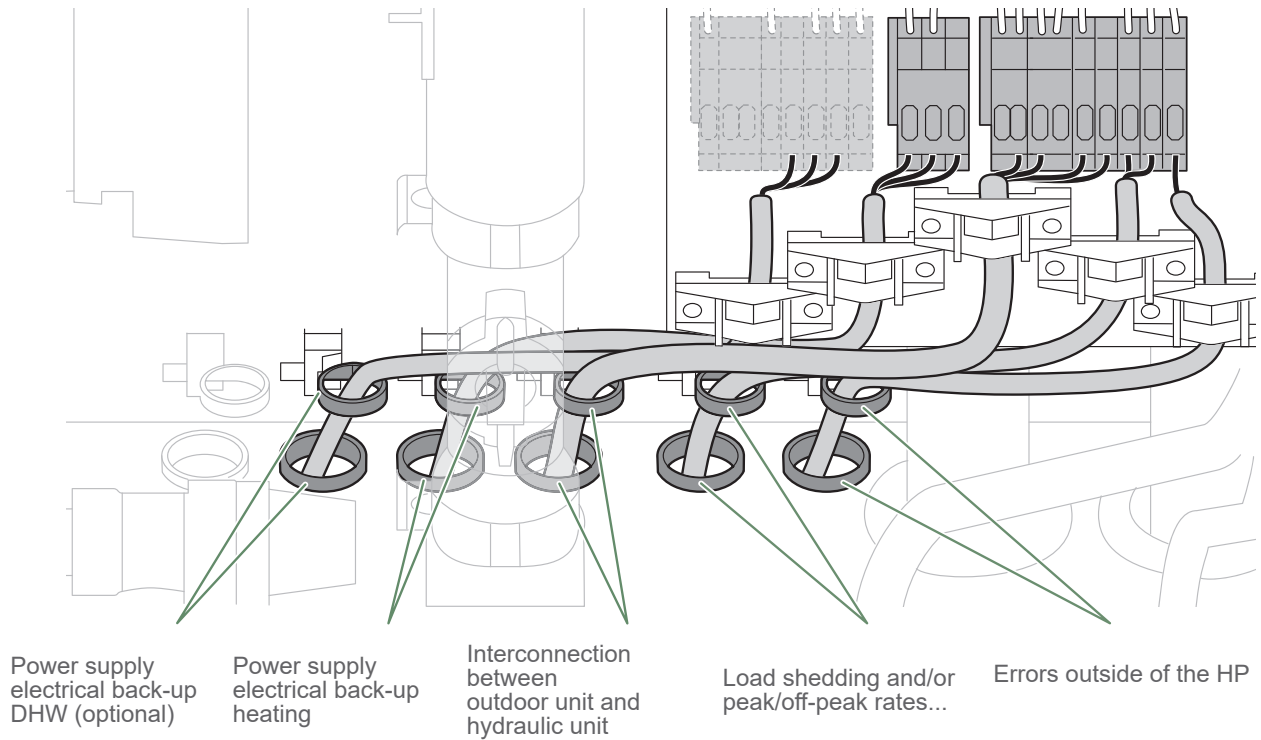
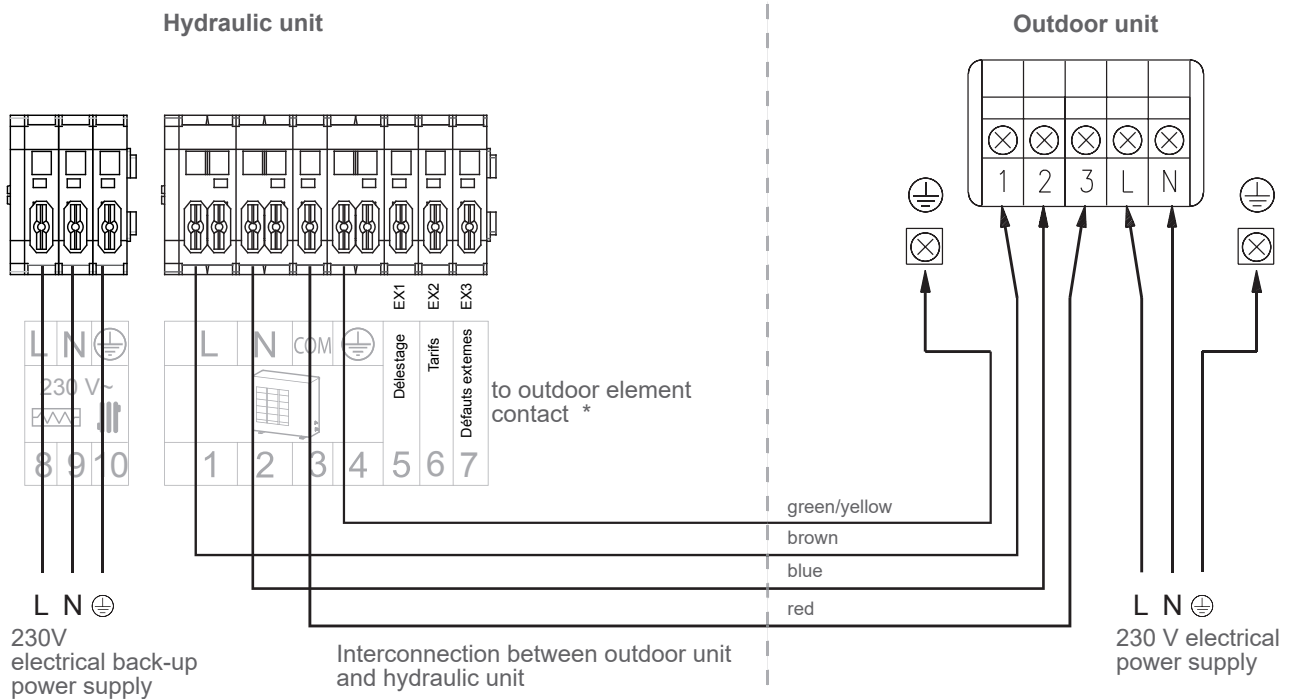

fig. 41 - LV cable bushing



* If the command does not supply a potential free contact, the contact must be relayed to obtain equivalent wiring.

In all cases, please refer to the instruction manuals for the external components (load shedder, etc.) to create the wiring.

fig. 42 - Connection to the terminal board (hydraulic unit)

▼ Interconnection between the outdoor unit and the hydraulic unit

Comply with the correspondence between the markings on the hydraulic unit's terminals and those on the outdoor unit when connecting the interconnection cables (fig. 42).

An incorrect connection can cause the destruction of one of the units.

▼ Electrical back-ups

Connect the power supply of the back-ups to the mains supply board (fig. 42).

▼ Domestic hot water tank (optional)

If the installation is equipped with a DHW tank (with electrical back-up):

- Please refer to the instructions supplied with the DHW kit.
- Please refer to the instructions supplied with the DHW tank.

▼ Contract with the power supplier.

The heat pump's operation can be controlled to suit special contracts:

Input	
EX1	Load shedding / peak shaving (to prohibit back-ups (and the compressor if parameter 79 = 1)).
EX2	Peak/Off-peak times (to control the switch to DHW comfort mode on the HP).
EX1 + EX2	Launch of DHW forced operation.

- Peak/off-peak rates, day / night rates

In particular, domestic hot water (DHW) at Nominal temperature will be produced during the off-peak hours when electricity is cheaper.

Connect the "energy supplier" contact to input **6** (Rates - EX2) fig. 42.

- Load shedding or peak shaving

The purpose of load shedding is to reduce the electrical consumption when it is too high compared to the contract with the energy supplier.

Connect the load shedder to input **5** (Load Shedding - EX1) fig. 42.

▼ Faults outside the heat pump

All information devices (thermostat, pressure switch, heated floor safety device, etc.) may indicate an external problem and stop the heat pump.

- Connect the external device to input **7** (External errors - EX3) fig. 42.
- 230 V on input **EX3** = heat pump shutdown (the system displays error **Er 73**).

▼ Energy meter

A signal is used to show the energy distribution for Heating/DHW functions by connecting a compatible energy meter. Depending on the appliance (refer to the meter's instructions manual):

① If the metering convention is:

0V for heating and 230V for DHW (applicable to the HP pack), connect the meter to terminals 18 (white) and 19 (grey) (fig. 43).

② If the metering convention is:

230V for heating and 0V for DHW, connect the meter to terminals 17 (black) and 18 (white) (fig. 44).

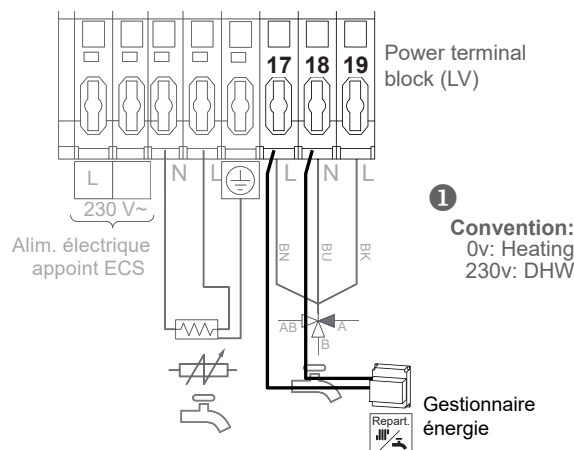

fig. 43 - Connection example (HP pack energy meter)

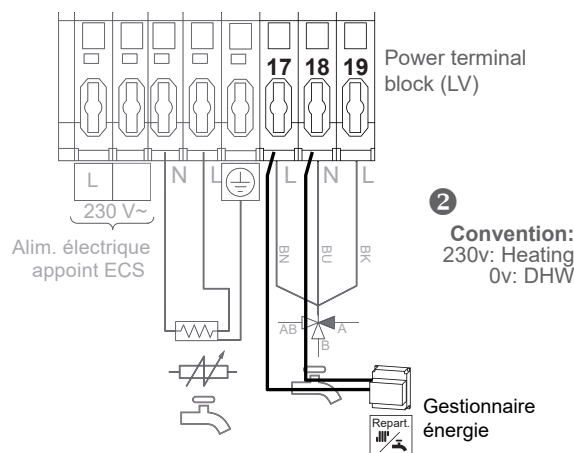

fig. 44 - Connection example (energy meter)



A series of horizontal dotted lines spanning the width of the page, providing a guide for handwriting practice.

► Electrical connections - SELV

The elements described below are Safety Extra-Low Voltage devices (SELV). Comply with the regulations applicable to such devices.

Comply with the safety distances between SELV and LV (power) cables.

Ensure that all of the electrical cables are housed in the spaces provided (fig. 45).

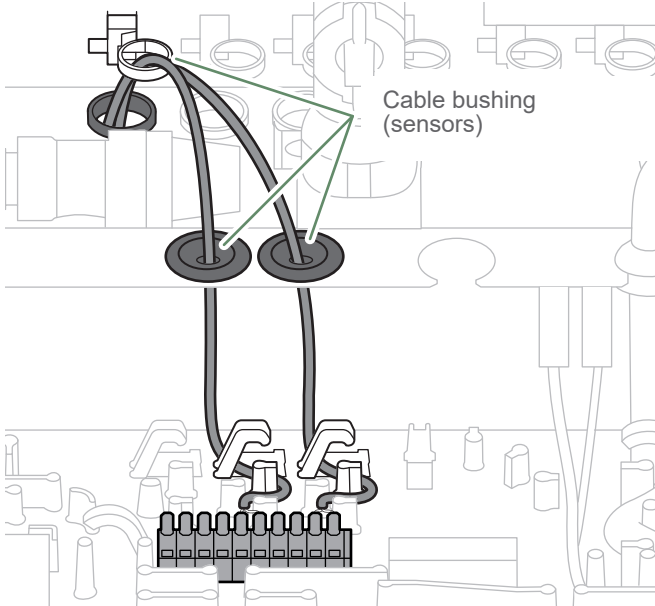

fig. 45 - SELV cable bushing

* Flexible wire mandatory.

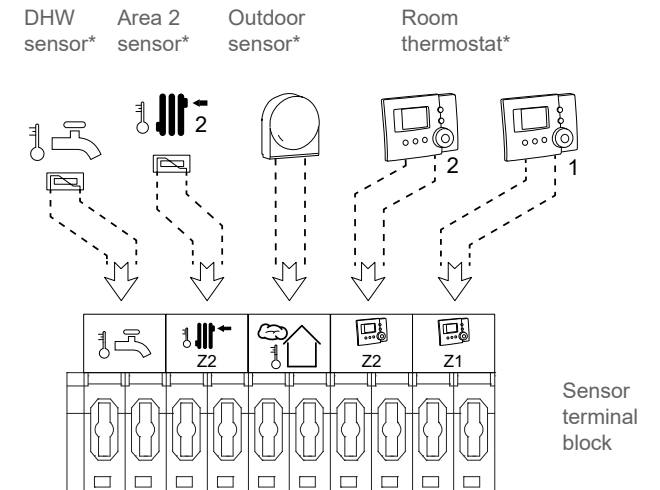

fig. 46 - Connections to the HP controller (accessories and options)

▼ Outdoor sensor (option)



**Without room accessories:
Outdoor sensor required**

Place the sensor on the coldest part, generally the northern or north-eastern side. In any case, it must not be exposed to the morning sun. It must be installed so that it is easily accessible but at least 2.5 m from the ground. Avoid sources of heat such as chimneys, the tops of doors or windows, nearby extraction ducts, underneath balconies and porches, that would insulate the sensor from the variations in the temperature of the outside air.

- Connect the outdoor sensor (fig. 46).

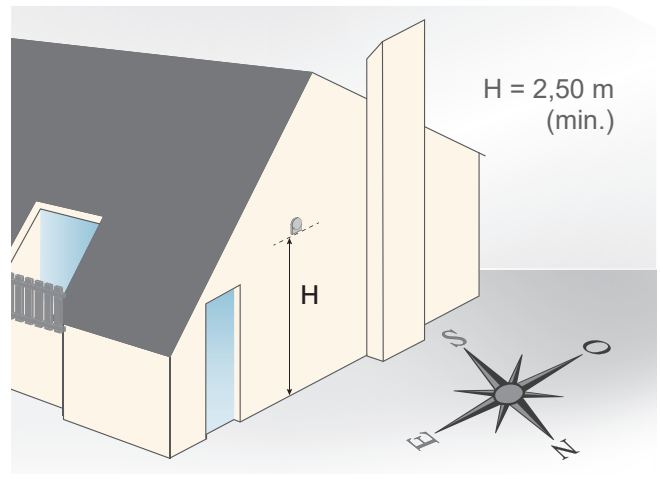

fig. 47 - Outdoor sensor (recommended exposure)

▼ Room thermostat (option)

Dynamic radiator or fan-coil area

If the installation is equipped with fan-coils / dynamic radiators, **do not use a room thermostat.**

Radiator or floor heating area

Consult the assembly instructions on the packaging of the sensor.

The thermostat must be installed in the area requiring control on a very uncluttered wall. It must be installed so as to be easily accessible. Avoid sources of direct heat (chimney, television, cooker, sunlight) and areas exposed to draughts (ventilation, doors).

Draughts due to the building usually cause cold air to enter via the electrical ducts. Seal the electrical ducts if there is a cold draught at the back of the room thermostat.

Connect the room thermostat 1 (*fig. 46*).

Connect the room thermostat 2 (*fig. 46*).

▼ Installing a Typass ATL (option)

Connect the Typass ATL to connector (*fig. 49*).

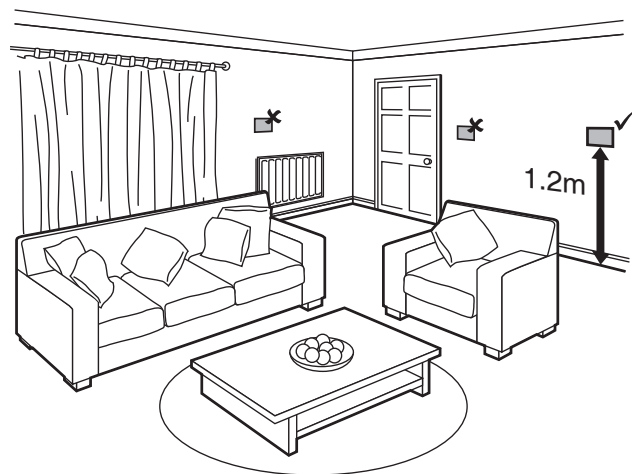

fig. 48 - Position of the room thermostat

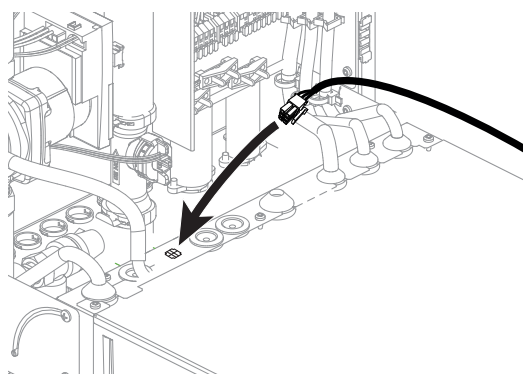
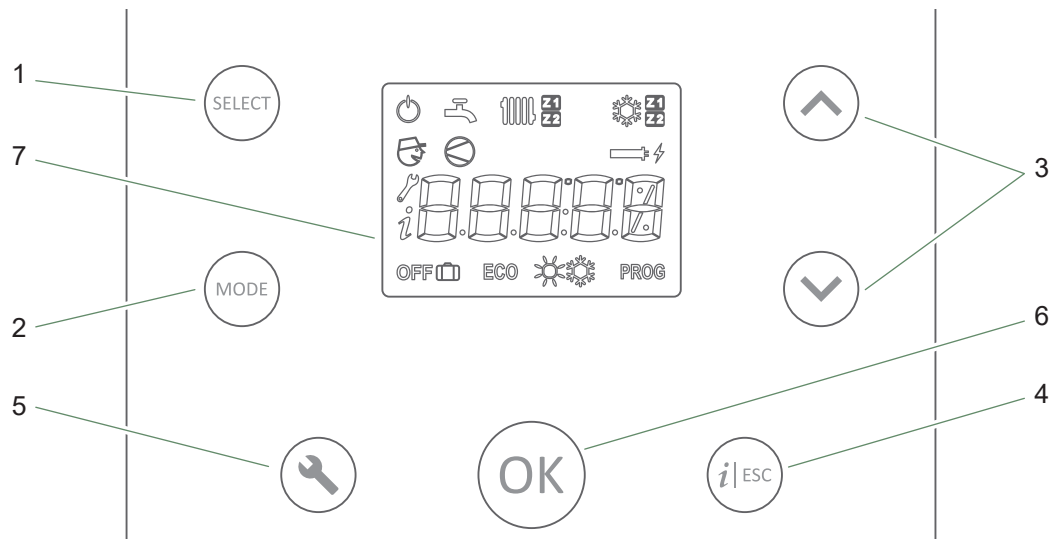







fig. 49 - Typass ATL connections

Controller Interface

► User interface



Ref.	Functions	- Definition of the functions
1	• SELECT	- Browse and select the available uses .
2	• MODE	- Browse and select the mode for the pre-selected use.
3	• Settings • Scrolling	- Configure the setpoints of the selected function using the  and  keys. - Scroll through the information and parameter lines. - Configure the modifiable values (after pressing OK to confirm).
4	• Information • "ESC" output	- Access the " information " menu (the  icon appears) - Exit the menu currently displayed - Cancel a modification being made
5	• Configuration	- Access the user level (press and release: the  icon appears). - Access the installer level (press and hold (for more than 5s): the  icon appears). List of parameters  : see page 51 .
6	• OK	- Confirm (Configuration, Setpoint for the pre-selected mode)
7	• Display	- Display: see § " Display Description ", page 45 - View the settings.

Some settings (or menus) might not be displayed. They are dependent on the installation's configuration (and installed options).

► Display Description

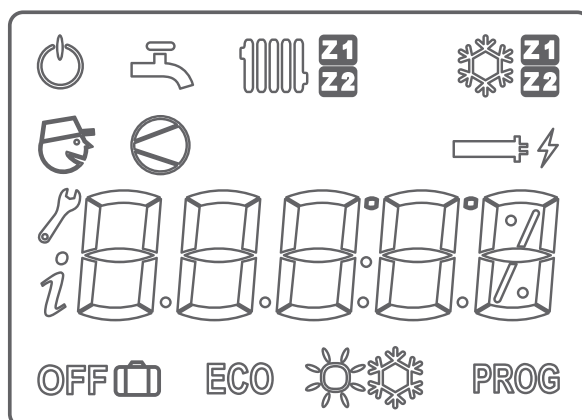

Icons	Definitions	Icons	Definitions
	Access the User settings	ECO	Constant mode (with reduced temperature setpoint)
	Use for heating (reference to the circuit concerned Z1 or Z2)	or	Constant mode for heating or cooling (with comfort temperature setpoint)
	Use for DHW		Absence mode
	Use for cooling (reference to the circuit concerned Z1 or Z2)	OFF	The use concerned is in Off mode (area 1 / 2 - DHW)
	Stand-by ⁽¹⁾		Read information
	Compressor operation		Access the Installer settings
	Electrical back-up operation (heating or DHW)		
PROG	PROG mode: Controlled operation according to the: - programme set in the User interface or the - programme set on the room thermostat		

⁽¹⁾ Frost protection provided that the electric power supply to the HP is not switched off.

Temperature control

The operation of the heat pump is controlled by the weather-dependent setpoint *.
The set temperature for the water in the heating circuit is adjusted according to the outdoor temperature.
If there are thermostatic valves on the installation, these must be fully open.

► Configuration

(depending on option, see [page 51](#))

During installation, the weather-dependent setpoint must be configured according to the heat emitters and the residence's insulation.

The weather-dependent setpoint curves ([fig. 50](#)) refer to an ambient setpoint of 20°C.

The weather-dependent setpoint slope (parameter **30/50** - see "[Heating setting, circuit 1 \(direct\)](#)", [page 52](#)) determines the impact of variations in outdoor temperature on the variations in initial heating temperature.

The steeper the slope, the more a slight reduction in the outdoor temperature causes a significant increase in the initial water temperature in the heating circuit.

The weather-dependent setpoint offset (parameter **31/51**) modifies the initial temperature of all the curves, without modifying the slope ([fig. 51](#)).

The corrective actions if discomfort is experienced are listed in the table ([fig. 52](#)).

► Room influence

(depending on option, see [page 51](#))

When the room influence is activated (parameter **33** for circuit 1 and **53** for circuit 2), the heating circuit water setpoint temperature is adjusted according to the outdoor temperature and the room temperature.

The room temperature's impact is weighted by this parameter, from 1 to 99%.

► Room control

(depending on option, see [page 51](#))

When the room influence is set to 100%, the heating circuit water setpoint is calculated only according to the difference between the room setpoint and the room temperature.

This operating mode provides better thermal comfort.

*depending on option

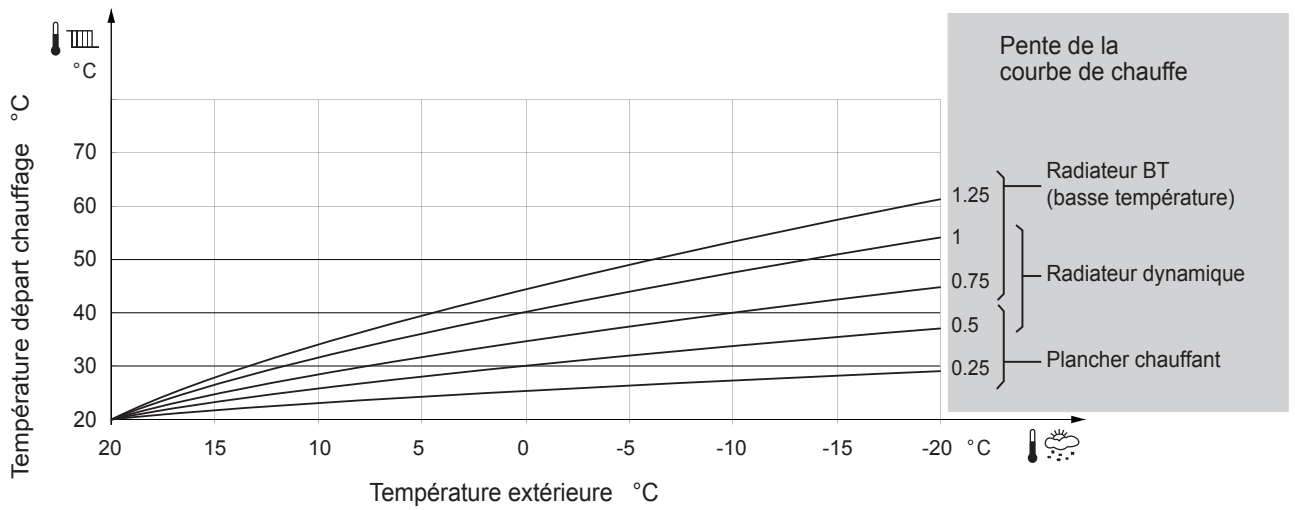

fig. 50 - Heating curve slope (line 30 / 50)

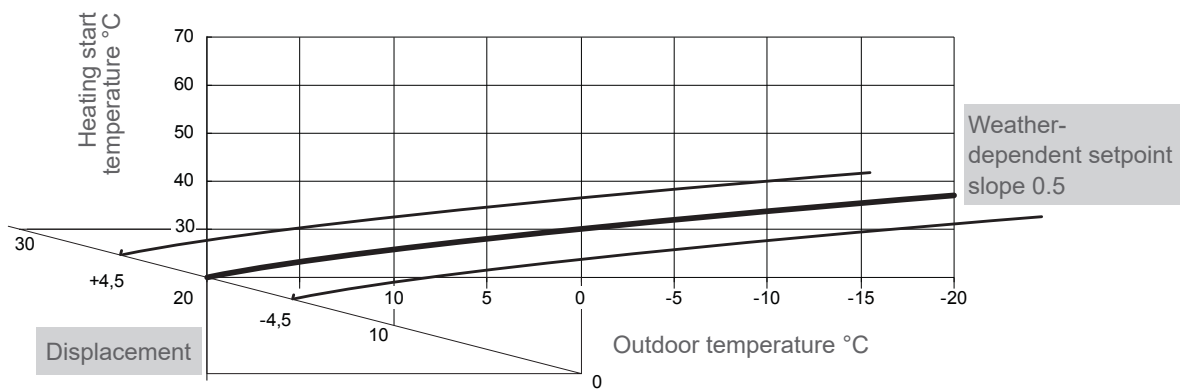

fig. 51 - Heating curve displacement (line 31 / 51)

Feelings...		Corrective actions on the weather-dependent setpoint:	
... in warm weather	... in cold weather	Slope (line 30 / 50)	Offset (line 31 / 51)
OK	& OK	→ No correction	No correction
Cold	& Hot	→ ▾	→ ▴
Cold	& OK	→ ▾	→ ▴
Cold	& Cold	→ No correction	→ ▴
OK	& Hot	→ ▾	No correction
OK	& Cold	→ ▴	No correction
Hot	& Hot	→ No correction	→ ▾
Hot	& OK	→ ▴	→ ▾
Hot	& Cold	→ ▴	→ ▾

fig. 52 - Corrective actions in case of discomfort

Commissioning

► Checks before commissioning

• Hydraulic circuit

- Make sure that the installation has been rinsed.
- Check the water flow direction and that all of the valves are open.

• Electrical circuit

- Check that the phase-neutral polarity of the electrical power supply is respected.
- Check that all the equipment is connected to the relevant connection terminals.

► Commissioning

▼ Filling and draining the installation

- Fill the installation.
- Perform a leak test for the whole installation.
- Do not operate the circulating pump while filling. Open all the drain valves in the installation to remove the air contained in the pipes.
- Close the drains and add water until the pressure of the hydraulic circuit reaches 1.5 bar.

▼ First power on

- Close the installation's main circuit breakers.

When first put into service (or in winter), to preheat the compressor, close the main circuit breakers of the installation (outdoor unit power supply) for several hours before the tests.

To guarantee the correct operation of inputs **EX1**, **EX2**, **EX3**: Check that the phase-neutral polarity of the electrical power supply is respected.

When put into service and every time that the main circuit breaker is cut off then reconnected, the outdoor unit requires approximately 3 minutes to start up even if the regulation has demanded heating.

While the regulator is being initialised the display shows all icons.

Note: When starting up the heating function after the HP has been fully shut down and for a heating network temperature not exceeding 17°C, the electrical back-up is automatically activated.

▼ Draining the hydraulic unit

On first power-up, the circulator pump and the directional valve (sanitary kit option) start to automatically purge the system (heating and sanitary circuits (sanitary kit option)). The user interface displays "AP"

The purge cycle takes about 4 minutes. Never stop this cycle. (During the purge cycle, the circulator pump alternates between operating phases and shutdown phases lasting 5 seconds (5 s on, 5 s off, etc.). The valve (sanitary kit option), alternates every 30 seconds between the heating circuit and the sanitary circuit.

- Open all the drain valves in the installation to remove the air contained in the pipes.
- Close the drains and add water until the pressure of the hydraulic circuit reaches 1.5 bar.

Precise filling pressure is determined by the manometric head of the installation.

- Check that there are no leaks.



To start a new automatic purge cycle: set setting "93" to 1 (automatic purge enabled).

▼ Setting the parameters

Configure all of the specific settings for the regulation (configuration of the installation in particular): list of settings *page 51*).

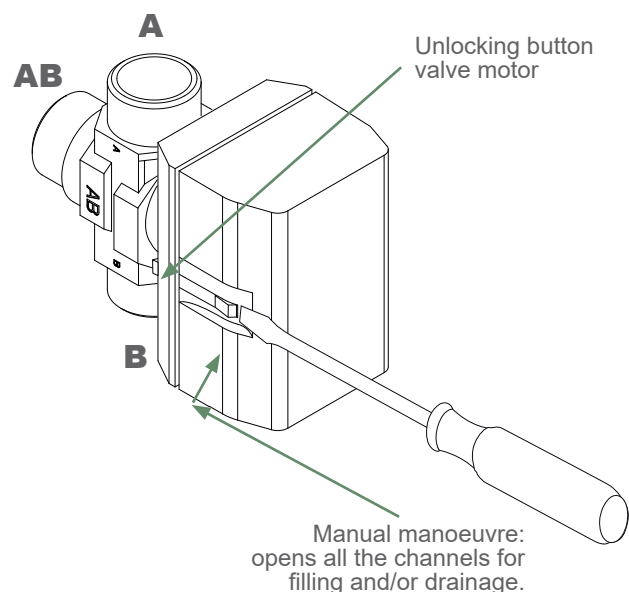
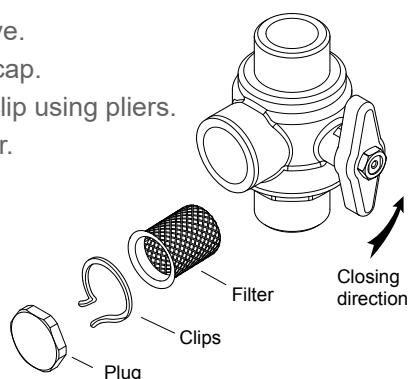

fig. 53 - Distribution valve (optional DHW kit)

► Cleaning the filter valve

Immediately after commissioning, clean the filter of the filter valve (remove waste generated by the installation: seals, oakum, filings, etc.).

- Close the valve.
- Unscrew the cap.
- Remove the clip using pliers.
- Clean the filter.



► Circulation pump operation

The speed of the heating circulation pump can be adjusted via the user interface (see "70", page 53). By default, the pump is set to the maximum speed (speed 4).

Circulation pump errors:

- If the flow rate is too low, error **Er 3** is displayed. The pump is shut down for a few minutes only, before trying again.
- If the problem persists, **Er 131** is displayed. The appliance then becomes locked: press "**OK**" to restart the appliance.

■ Circulation pump operating signals

	LED Off	The pump does not work, no electrical power.
	Green LED on	The pump works normally
	Green/Red LED blink	Circulation pump operation in "alert" mode (under unusual conditions such as: dry running, motor overload due to impurities in the water, etc.).
	Red LED blink	Operating error due to a persistent external fault (abnormal voltage/current, external pump blockage, reverse flow, etc.). Circulation pump stops. The circulation pump restarts once the issue is resolved.
	Red LED on	Operating error / Permanent shutdown. Circulation pump replacement.

► Floor drying mode



The control can be configured to manage the floor drying function of the floor heating system (parameter "88" & "89", page 54).

The parameter must be set to "**Off**" to deactivate the floor drying mode.

Controller Menu

► Overview

Two viewing modes are available:

-  - User.
-  - Installer.

The access levels are specified in the second column of the table with the corresponding icons.

► Setting parameters



▼ Recommended settings for the parameters depending on the installation's transmitters

Heating		VLT Radiators / Heating-cooling floor	Low temperature radiators	Classic temperature radiators	Dynamic radiators or fan-coil heaters
Heating curve slope	30 (CC1)	0.25 to 0.5	0.5 to 1.25	1.25 to 3	0.4 to 1.1
	50 (CC2)				
Curve off-set	31 (CC1)	0	0	0	4
	51 (CC2)				
Max. initial setpoint	32 (CC1)	55°C (factory setting)	55°C (factory setting)	55°C (factory setting)	55°C (factory setting)
	52 (CC2)				
Influence of room temp.	33 (CC1)	With room thermostat. The settings depend on the accuracy of the temperature measured by the room thermostat (and therefore of its installation - see page 43).			0% (room thermostat prohibited)
	53 (CC2)				
Emitter type	35 (CC1)	1*	0	0	0
	55 (CC2)				

* System with underfloor heating, ensure that the underfloor heating safety device is connected.

▼ Settings according to the room accessories

With Typass ATL

→ The HP operates based on temperature control (see page 46).

Set:

- the temperature control
- the room T° influence
- the room control.



Settings on the typass

- Heating settings
 - Mode selection.
 - Setting the room setpoints.
 - Setting the programming times.

With Navilink 105 / 128

→ The circuit water temperature setpoint is calculated by the Navilink and then communicated to the HP.



Settings on the Navilink 105 / 128

- Heating settings
 - Mode selection.
 - Setting the room setpoints.
 - Setting the programming times.

Without room accessories

→ The HP operates based on temperature control (see page 46).



Set:

- the temperature control













Outdoor sensor required











Setting the initial heating setpoint

This setting is made directly using the  and  keys. Confirm with **OK** (+/-5 compared to the value calculated by the temperature control).





► List of parameters

No.	Description of parameter	Configuration or display range	Basic setting
0	 Switch heating / cooling	0 (heating)... 1 (cooling)	0
Time / Date setting			
1	 Hours / minutes	00:00... 23:59	01:00
2	 Month / Day	1 - 12 1 - 31	MM-DD
3	 Year	2021 ...	YYYY
Installation configuration			
4	 Two heating circuits option This control enables you to choose one of the 2 pre-selected installation configurations. 1 (1 heating circuit) ; 2 (not used) ; 3 (2 heating circuits with uncoupling bottle).	1 ... 3	1
5	 Domestic hot water option	1 (heating only)... 2 (heating + DHW)	1
6	 General cooling authorisation.	0 (not allowed)... 1 (allowed)...	0
7	 Heating back-up prohibited	0 (no)... 1 (yes)	0
8	 DHW back-up prohibited	0 (no)... 1 (yes)	1
9	 Software version	0... 99	-

Some settings (or menus) might not be displayed. They are dependent on the installation's configuration (and installed options).

No.	Description of parameter	Configuration or display range	Basic setting
Absence mode			
10	 Absence mode temperature setpoint Adjustment of the temperature setpoint used during absence mode.	5 °C... 20 °C	13 °C
11 → 24 : Parameters not used			
DHW timer programme			
25	 Pre-selection (day / week) 1 = Monday; 2 = Tuesday... 7 = Sunday; 8 = Monday to Friday; 9 = Saturday and Sunday 10 = Monday to Sunday (modifications are applied to the whole week)	1 ... 10	-
26	 1st phase of the selected day (start of comfort)	00:00... 23:45	00:00
27	 1st phase of the selected day (end of comfort)	00:15... 24:00	5:00
28	 2nd phase of the selected day (start of comfort)	00:00... 23:45	14:30
29	 2nd phase of the selected day (end of comfort)	00:15... 24:00	17:00
Heating setting, circuit 1 (direct)			
30	 Heating curve slope	0.10... 4.00	0,7
31	 Heating curve displacement	-4.5... 4.5°C	0 °C
32	 Max. initial heating setpoint	20... 55°C	50 °C
33	 Room temperature influence If the installation is fitted with a room thermostat (area 1): This function enables you to choose the ambient temperature's influence on the setting. If no value is entered, only the weather-dependent setpoint is configured.	0... 100%	50%
35	 Zone 1 emitter type	0 (Radiator)... 1 (Underfloor heating)	0
37	 Zone 1 mid-season economy The heating request stops when the exterior temperature is higher than the setpoint +1°C	0 (off)... 1 (on)	0
Cooling setting, circuit 1 (direct)			
40	 Cooling authorisation (circuit 1)	0 (no)... 1 (yes)	0
41	 Cooling curve slope	0.10... 4.00	0,7
42	 Cooling curve displacement	-4.5... 4.5°C	0 °C
43	 Min. initial cooling setpoint	5... 30 °C	10 °C

Some settings (or menus) might not be displayed. They are dependent on the installation's configuration (and installed options).

No.	Description of parameter	Configuration or display range	Basic setting
Heating setting, circuit 2 (combined)			
50	 Heating curve slope	0.10... 4.00	0,7
51	 Heating curve displacement	-4.5...4,5 °C	0 °C
52	 Max. initial heating setpoint	20... 55 °C	45 °C
53	 Room temperature influence	0... 100%	50%
	If the installation is fitted with a room thermostat (area 2): This function enables you to choose the ambient temperature's influence on the setting. If no value is entered, only the weather-dependent setpoint is configured.		
55	 Zone 2 emitter type	0 (Radiator)... 1 (Underfloor heating)	0
57	 Zone 2 mid-season economy	0 (off)... 1 (on)	0
	The heating request stops when the exterior temperature is higher than the setpoint +1°C		
Cooling setting, circuit 2 (combined)			
60	 Cooling authorisation (circuit 2)	0 (no)... 1 (yes)	0
61	 Cooling curve slope	0.1... 4.00	0,7
62	 Cooling curve displacement	-4.5...4,5 °C	0
63	 Min. initial cooling setpoint	5... 30 °C	10 °C
Circulation pump			
70	 Pump speed	1... 4	4
Heat pump			
71	 Heating standby switchover authorisation	0 (manual)... 1 (automatic)	1
72	 Automatic change in state according to the outdoor temperature (heating <> stand by).	15... 30 °C	18 °C
	When the average of the outdoor temperatures reaches 18°C, the regulator switches off the heating (as an economy measure).		
73	 Legionella function	0 (off)... 1 (on)	0
	If the function is activated, check that the parameter 8 (DHW back-up prohibited) is set to 0 (no). When the function is activated, the Legionella cycles take place on Friday at 3 a.m.		

Some settings (or menus) might not be displayed. They are dependent on the installation's configuration (and installed options).

No.	Description of parameter	Configuration or display range	Basic setting
74	Correction of outdoor temperature sensor	- 5... 5 °C	-
75	Behaviour of the appliance when suffering from an external error - EX3 (see table page 59).	1 (appliance locked) 2 (Area 1 off) 3 (Area 2 off)	1
76	Parameters not used		
77	Direction of action input 5 (Load Shedding - EX1)	0 (Load shedding or peak shaving if 0V, Normal operation if 230V)... 1 (Load shedding or peak shaving if 230V, Normal operation if 0V)	
78	Direction of action input 6 (Rates - EX2)	0 (off-peak if 0V, peak if 230V)... 1 (off-peak if 230V, peak if 0V)	
79	Compressor load shedding forbidden	0 (no)... 1 (yes)	0
80	EU reference power	0... 10,0 kW	-

Adjust according to the appliance's power:

	Model 4, 6	Model 8	Model 10
	WOYA060KLT	WOYA080KLT	WOYA100KLT
kW	1.9	2.5	3.5

81	DHW electrical back-up power	0... 10,0 kW	-
Adjust according to the DHW tank's power.			
82	Activation of summer time	0 (no)... 1 (yes)	1
83	DHW max temperature	45°C ... 65°C	65°C
88	Zone 1 tile drying	0 (off) 1 (permanent) 2 (Mode 2) 3 (Mode 3)	0

Permanent: This mode is used to manually configure the initial constant heating setpoint for each circuit.

Mode 2 / Mode 3:

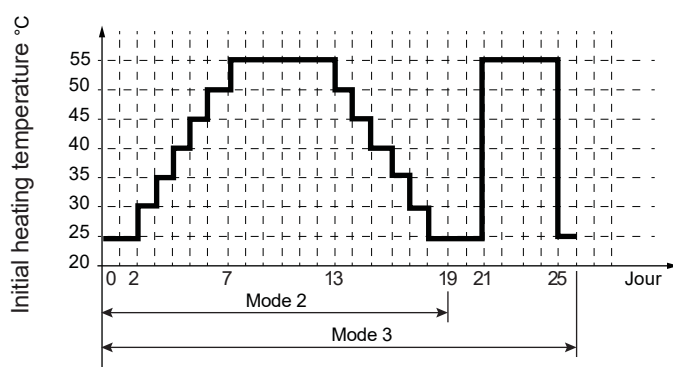









Respect the standards and values of the building constructor!

Correct operation of this function is only possible with a correct installation (hydraulic, electricity and settings)!

This function can be stopped early by setting it to "Off"..

89	Zone 2 tile drying	0 (off) 1 (permanent) 2 (Mode 2) 3 (Mode 3)	0
----	--------------------	--	---

Some settings (or menus) might not be displayed. They are dependent on the installation's configuration (and installed options).

No.	Description of parameter	Configuration or display range	Basic setting
90	 Manual heating mode	0... 30	---
91	 Manual air-conditioning mode	0... 30	---
92	 3-way valve position during manual mode	0 (heating)... 1 (DHW)	0
93	 Manual activation of the purge sequence	0 (no)... 1 (yes)	0
95	 DHW boost	0 (off)... 1 (on)	0
96	 Appliance test	0... 9	-
<p>This parameter is used to test the components connected to the controller. It is used to check that the relays are operating and that the wiring is correct (for this, check that each appliance is operating on the installation). The test automatically stops after 20 minutes.</p> <p>During the tests, the HP safety devices are deactivated. An ongoing test must be stopped in all cases when the component operation is validated (reset the parameter to 0).</p> <p>0 = No test; 1 = Compressor test (the HP starts at 50% as well as all circulation pumps); 2 = Heating electrical back-up test + internal circulation pump test; 3 = Distribution valve test (heating position); 4 = Distribution valve test (DHW position); 5 = DHW electrical back-up test; 6 = Mixing valve (closed position) and circulation pump test for 2nd circuit; 7 = Mixing valve (open position - direct circulation) and circulation pump test for 2nd circuit; 8 = Circulation pump test for circuit 1; 9 = Circulation pump test for circuit 2; 10 = Operation of all circulation pumps.</p>			
97	 Assist mode	0 (Assist mode off)... 1 (Assist mode on)	0
98	 Reset of operating counters	1 (reset)	-
100	 Attenuation mode activation	0 (arrêt)... 1 (marche)	0
101	 Maximum modulation in silent mode	30...100%	50%
102	 Attenuation mode - start of phase 1	00:00... 23:15	00:00
103	 Attenuation mode - end of phase 1	00:15... 24:00	07:00
104	 Attenuation mode - start of phase 2	00:00... 23:15	22:00
105	 Attenuation mode - end of phase 2	00:15... 24:00	24:00
106	 Attenuation mode - start of phase 3	00:00... 23:15	---
107	 Attenuation mode - end of phase 3	00:15... 24:00	---
108	 Outdoor temperature limit - silent mode	-15...30°C	5°C

Some settings (or menus) might not be displayed. They are dependent on the installation's configuration (and installed options).

► Displaying information

The **i**^{ESC} button calls up various information.

Depending on the appliance type, the configuration and the state of operation, certain information lines may not be available.

■ List of information

i No...	Name	Value...
1	Time.	hh:mm
2	Outdoor temperature.	... °C
3	Circuit 1: Initial temperature.	... °C
4	Circuit 1: Initial setpoint.	... °C
5	Return temperature.	... °C
6	Flow measurement.	... l/min
7	Compressor modulation level.	... %
8	Heating back-up status.	0 = off 1 = on
9	Circuit 2: Initial temperature.	... °C
10	Circuit 2: Initial setpoint.	... °C
11	DHW temperature.	... °C
12	DHW setpoint.	... °C
13	HP status.	see details § "Status list"
14	Heating circuit 1 status.	
15	Heating circuit 2 status.	
16	DHW circuit status.	
17	DHW back-up status.	0 = off 1 = on
18	Outdoor unit error code.	(see table page 60).
Energy consumption		Value...
30	Heat. - Energy consumed this month	... kWh
31	Heat. - Energy consumed last month	... kWh
32	Heat. - Energy consumed this year	... MWh
33	Heat. - Energy consumed last year	... MWh
40	Cool. - Energy consumed this month	... kWh
41	Cool. - Energy consumed last month	... kWh
42	Cool. - Energy consumed this year	... MWh
43	Cool. - Energy consumed last year	... MWh
50	DHW - Energy consumed this month	... kWh
51	DHW - Energy consumed last month	... kWh
52	DHW - Energy consumed this year	... MWh
53	DHW - Energy consumed last year	... MWh

Operating counter		
60	Number of hours HP ON	... h
61	Total number of compressor starts	---
62	Number of hours in DHW (compressor OFF or ON)	... h
63	Number of hours in DHW (compressor ON)	... h
64	Number of compressor starts in DHW	---
65	Number of hours with DHW back-up ON	... h
66	Number of hours of heating (compressor OFF or ON)	... h
67	Number of hours of heating (compressor ON)	... h
68	Number of compressor starts in heating	---
69	Number of hours with heating back-up ON	... h
70	Number of hours of air-conditioning (compressor OFF or ON)	... h
71	Number of hours of air-conditioning (compressor ON)	... h
72	Number of compressor starts in air-conditioning	---
73	Number of hours main circulator pump ON	... h

■ Status list

<i>i</i> No.	Value...	HP status
13	0	Pending.
	1	Heating.
	2	Cooling.
	3	Error.
	4	Assist mode.
	5	Locked.
	6	Defrost activated.
	7	Test mode.
<i>i</i> No.	Value...	Heating circuit 1 and 2 status
14 & 15	0	Pending.
	1	Comfort heating mode.
	2	Reduced heating mode.
	3	Comfort cooling mode.
	4	Reduced cooling mode.
	5	Absence mode.
	6	Controlled by the room thermostat.
	7	Frost protection activated.
	8	Floor drying mode.
	9	Rate input activated.
<i>i</i> No.	Value...	DHW status
16	0	Pending.
	1	Comfort mode, charge activated.
	2	Reduced mode, charge activated
	3	Legionella charge.
	4	Frost protection activated.
	5	Forced operation. (boost)

Troubleshooting

► Hydraulic unit errors

The faults or breakdowns of the hydraulic unit are reported on the display unit of the user interface. The display shows the "Erxxx" error code. A minor error does not result in switching the appliance to safety mode. A major error results in switching the appliance to safety mode. After solving the problem, press **OK**(reset and cancel the error message).

Visible faults on the digital display.

Error codes		Description	Switched to safety mode	Probable causes
Minor error	Major error			
3	-	Hydraulic flow rate too low.	-	Circulation pump speed settings too low. Clogged filter valve.
-	131		(Appliance shutdown if the error 3 occurs 3 times in 1 hour)	
5	-	Initial temperature (T5) or return temperature (T6) < 2 °C	-	Frost protection function defective. Back-up disconnected.
6	-	Communication error between the interface board and the HP regulator board.	-	Check the wiring.
19	-	Test mode activated.	-	-
35	-	HP outgoing flow sensor error (T5).	-	Short circuit, sensor disconnected or cut off. Defective sensor. Other error.
36	-	HP return flow sensor error (T6).	-	Short circuit, sensor disconnected or cut off. Defective sensor. Other error.
-	132	Initial temperature > 70 °C (T5)	-	
46	-	Circuit 2 sensor error (T12)	-	Short circuit, sensor disconnected or cut off. Defective sensor. Other error.
48	-	Outdoor temperature sensor error (T7)	-	Short circuit, sensor disconnected or cut off. Defective sensor. Other error.
47	-	DHW tank sensor error (T8)	-	Short circuit, sensor disconnected or cut off. Defective sensor. Other error.
-	148	Legionella cycle error	This error appears if 3 consecutive tests fail.	DHW back-up disconnected.
52	-	Frost detected on the return circuit when defrosting the outdoor unit (temperature < 2 °C).	-	Circulating water volume too low (see table page 7).
-	180		Appliance shutdown if the error 52 occurs 3 times in 1 hour.	
53	-	Frost detected on the outgoing circuit when defrosting the outdoor unit (temperature < 3 °C).	-	
-	181		Appliance shutdown if the error 53 occurs 3 times in 1 hour.	
55	-	Frost protection of the HP circuit activated (with electrical back-up)	-	-



Before performing any maintenance, make sure that all power supplies have been cut off.

Stored energy: after cutting off the power supplies, wait for 10 minutes before accessing the internal parts of the equipment.

Frost protection is not available when the heat pump is not powered up.



Visible faults on the digital display.					
Error codes		Description	Switched to safety mode	Probable causes	
Minor error	Major error				
56	-	Frost protection of the DHW tank activated (with electrical back-up)	-	-	
62	-	Load shedding - peak shaving or rate input activated	-	-	
66	-	Outdoor unit error (external cause)	-	See <i>"Outdoor unit errors"</i> , page 60	
67	-	DHW cycle too long (> 6 hours).	-	Too much draw-off during the same cycle. DHW back-up disconnected.	
-	195		Appliance shutdown if the error 67 occurs 3 consecutive times.		
68	-	Room temperature in area 1 missing.	-	Room unit disconnected or absent.	
69	-	Room temperature in area 2 missing.	-	Room unit disconnected or absent.	
70	-	Assist mode activated.	-	-	
71	-	Circuit temperature 2 > 55 °C	-	Defective mixing valve.	
73	-	External error linked to input EX3.	Parameter 75 set to ...	1 -> HP locked	Outdoor component error.
				2 -> Area 1 shut down	
				3 -> Area 2 shut down	
76	-	Low hydraulic flow rate.	-	Circulation pump speed settings too low. Clogged filter valve.	





Before performing any maintenance, make sure that all power supplies have been cut off.

Stored energy: after cutting off the power supplies, wait for 10 minutes before accessing the internal parts of the equipment.

Frost protection is not available when the heat pump is not powered up.



► Outdoor unit errors

In the event of an error occurring within the outdoor unit, the user interface displays the "Er 66" error code. View the information menu  | ESC : Information "No. 18" specifies the error code for the outdoor unit "xx" (list provided below).

Error	Interface Board		Error designation (models 4, 6 and 8)	Error designation (model 10)
	LED Green	LED Red		
11	1	1	Serial communication error	
23	2	3	Combination Error	
32	3	2	UART communications error	
42	4	2	Hydraulic unit heat-exchange thermistor error	
62	6	2	Outdoor unit main PCB error	
63	6	3	-	Inverter error
65	6	5	Outdoor unit IPM error	
71	7	1	Discharge thermistor error	
72	7	2	Compressor thermistor error	
73	7	3	-	Heat-exchange thermistor error (centre)
			Heat-exchange thermistor error (outlet)	Heat-exchange thermistor error (outlet)
74	7	4	Outdoor thermistor error	
77	7	7	-	Heat sink thermistor error (P.F.C.)
78	7	8	Expansion valve thermistor error	
84	8	4	Current sensor error	
86	8	6	Pressure sensor error / Pressure switch error	
94	9	4	Current tripped (permanent stoppage)	
95	9	5	Detection of compressor position error (permanent stoppage)	Compressor motor control error (permanent stoppage)
97	9	7	Outdoor unit fan motor error	
A1	10	1	Discharge temperature protection (permanent stoppage)	
A3	10	3	Compressor temperature protection (permanent stoppage)	
A5	10	5	Low pressure abnormal	Pressure error
AC	10	12	-	Outdoor unit radiator temperature error



Before performing any maintenance, make sure that all power supplies have been cut off.

Stored energy: after cutting off the power supplies, wait for 10 minutes before accessing the internal parts of the equipment.

Frost protection is not available when the heat pump is not powered up.



▼ Outdoor Unit : modèle 10

When an error occurs:

- The LED "ERROR" (2) blinks.
- Press once on the switch "ENTER" (S132).
- The LED blinks several times depending on the error's type (see below).

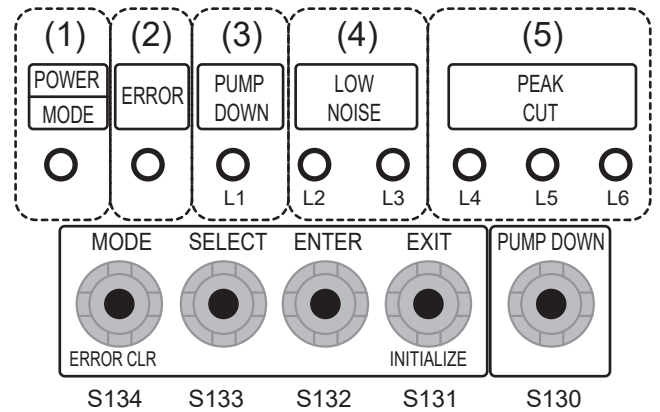

o : LED Off ; ● : LED on

Error	Outdoor Unit Board						Error designation
	(L1)	(L2)	(L3)	(L4)	(L5)	(L6)	
11	1	1	o	o	●	●	Serial communication error after operation
	1	1	o	●	o	o	Serial communication error during operation
23	2	3	o	o	o	●	Different combinations used by indoor and outdoor units
62	6	2	o	o	o	●	Outdoor unit main PCB error
63	6	3	o	o	o	●	Inverter error
65	6	5	o	o	●	●	Outdoor unit IPM error
	6	5	o	o	o	●	IPM board temperature error
71	7	1	o	o	o	●	Discharge thermistor error
72	7	2	o	o	o	●	Compressor thermistor error
73	7	3	o	o	●	o	Heat-exchange thermistor (intermediate) error.
	7	3	o	o	●	●	Heat-exchange thermistor (outlet) error.
74	7	4	o	o	o	●	Outdoor thermistor error
77	7	7	o	o	o	●	Outdoor unit heat sink temp. thermistor error
78	7	8	o	o	o	●	Expansion valve thermistor error
84	8	4	o	o	o	●	Current sensor error
86	8	6	o	●	o	o	Pressure switch error
	8	6	o	●	●	o	Pressure sensor error
94	9	4	o	o	o	●	Trip detection
95	9	5	o	o	o	●	Detection of compressor position error Compressor start up error
97	9	7	o	o	●	●	Outdoor unit fan1 motor error
A1	10	1	o	o	o	●	Discharge temperature protection
A3	10	3	o	o	o	●	Compressor temperature protection
A5	10	5	o	o	o	●	Low pressure abnormal
AC	10	12	o	o	●	●	Outdoor unit radiator temperature error

► Safety thermostat

When the temperature in the electrical back-up exceeds 90°C, the HP is stopped by its overheating safety device. Always check that the electric power supply is switched off before works.

⚠ Stored energy: after disconnecting the power supplies, wait 1 minute before accessing the internal parts of the equipment.

Remove the expansion vessel (*fig. 56*) and reset when the water temperature has returned to normal.

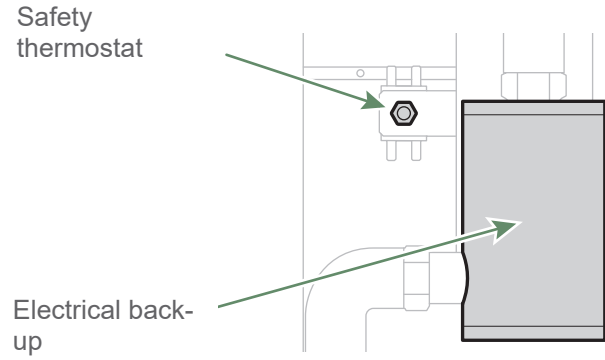

*fig. 54 - Reset button
(overheating safety device)*



A series of horizontal dotted lines spanning the width of the page, providing a guide for handwriting practice.

Maintaining the installation



Before performing any maintenance, make sure that all power supplies have been cut off.

Stored energy: after cutting off the power supplies, wait for 10 minutes before accessing the internal parts of the equipment.



► Hydraulic checks

Regular maintenance is required to protect the HP.

Note: Protection via the detection of the minimum flow rate stops the HP under poor operating conditions (clogged filter, water shortage, etc.).

Depending on the frequency described below, clean the filter valve (where necessary the sediment trap) and check the pressure.

- Immediately after commissioning (remove waste generated by the installation: seals, oakum, filings, etc.),
- In the first two months after commissioning and depending on the type of installation,
- Then during each maintenance operation (remove particulate matter and sediment contained in the heating water).

▼ Cleaning the filter valve

- Close the valve.
- Unscrew the cap.
- Remove the clip using pliers.
- Clean the filter.

▼ Cleaning the sediment trap

Refer to the manufacturer's instructions.

▼ Annual inspection

Check the heat output: assessment with the temperature deviation (outgoing - return) and flow rate.

Warning: If frequent refills are required it is essential that you look for any leaks.

If you need to fill up and reset the pressure, check the type of fluid originally used.

Recommended filling pressure: between 1 and 2 bar (the exact filling pressure is determined according to the installation's manometric head).

Every year.

- Check the expansion vessel pressure (pre-inflation of 1 bar) and the correct operation of the safety valve.

If the installation is fitted with a DHW tank:

- Verify the safety unit on the cold water supply inlet.
- Run it according to the manufacturer's instructions.
- Check the disconnecter.

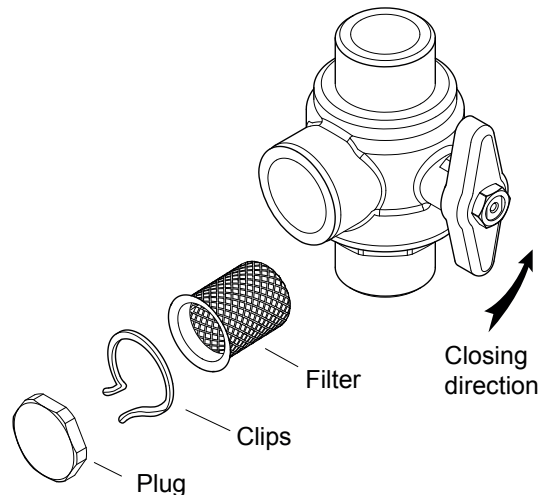

fig. 55 - Filter valve: filter removal

► Checking the outdoor unit

- Remove any dust from the exchanger making sure you do not damage the blades.
- Correct the blades using a comb.
- Check that there is nothing hindering the air flow.
- Check the fan.
- Check that the condensate discharge is not blocked.

• Checking the refrigeration circuit

- Check that there are no leaks (connectors, valves, etc.).

► Electrical checks

- Check connections and tighten where necessary.
- Check the condition of the cabling and plates.

Maintenance



Before performing any maintenance, make sure that all power supplies have been cut off.

Stored energy: after cutting off the power supplies, wait for 10 minutes before accessing the internal parts of the equipment.

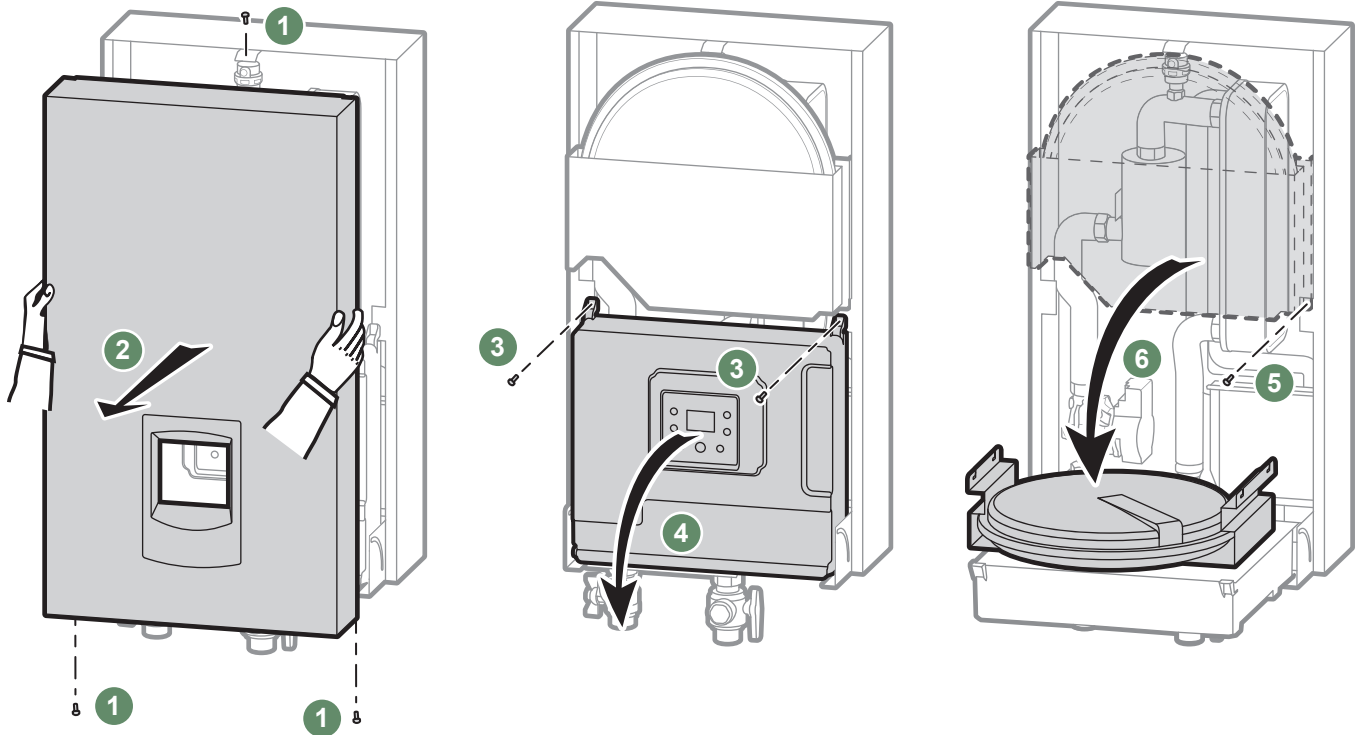

fig. 56 - Removable expansion vessel

► Draining the hydraulic unit

- Close the valves (pressure gauge and filter valves).
- Open the bleed tap.
- Open the installation air bleeder.

► Replacing fuses

The fuses are located on the printed circuit boards and the supply bundle (see *page 74*).

Fuse properties:

- T3.15AH250V, 5x20 mm, IEC 60127-1,
- T6.3AH250V, 5x20 mm, IEC 60127-1.

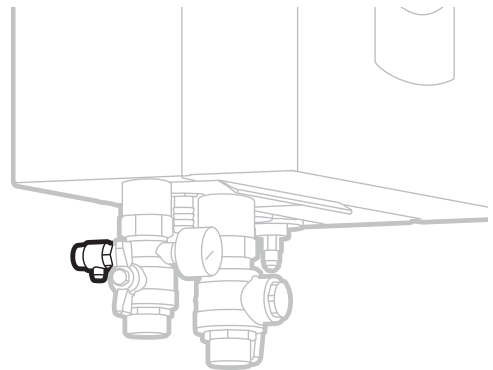

fig. 57 - Bleed tap

► Filling the installation with gas



This operation is reserved for installers familiar with the legislation for handling refrigerants. Creating a vacuum with a calibrated vacuum pump is essential (see APPENDIX 1). Never use equipment used previously with any refrigerant other than a HFC. Only remove the refrigeration circuit caps when performing the refrigeration connections.

If the outdoor temperature is below +10°C:

- You must use the triple evacuation method (see APPENDIX 2).
- We recommend installing a dehydrator filter (and this is highly recommended if the outdoor temperature is below +5°C).

APPENDIX 1

Method for calibrating and checking a vacuum pump

- Check the vacuum pump's oil level.
 - Connect the vacuum pump to the vacuum gauge as shown in the diagram.
 - Pump down for 3 minutes.
 - After 3 minutes, the pump reaches its threshold vacuum limit and the vacuum gauge's needle stops moving.
 - Compare the obtained pressure value against the table of values. Depending on the temperature, this pressure should be lower than that shown in the table.
- => If this is not the case, replace the gasket, hose or pump.

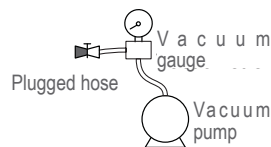

T °C	5°C < T < 10°C	10°C < T < 15°C	15°C < T
Pmax - bar	0.009	0.015	0.020
- mbar	9	15	20

APPENDIX 2

Triple Evacuation Method

- Connect the *Manifold* high-pressure hose to the filling hole (gas connection). A valve must be fitted to the vacuum pump's hose so you can shut it off.

a) Create a vacuum until the desired value is reached and maintain this value for 30 mins (see table in APPENDIX 1),

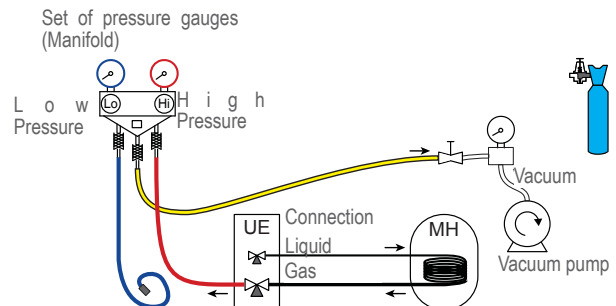

b) Switch off the vacuum pump, close the valve at the end of the service hose (yellow), connect this hose to the expansion valve on the nitrogen bottle, fill to 2 bar, close the hose's valve again,

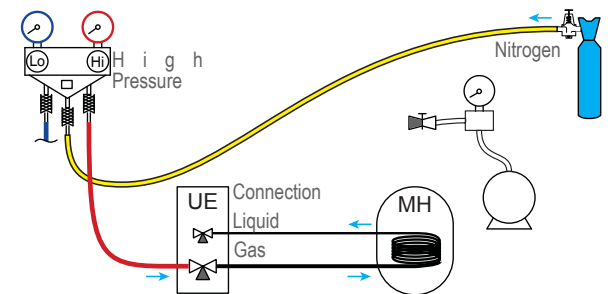

c) Connect this hose to the vacuum pump again, switch it on and slowly open the hose's valve.

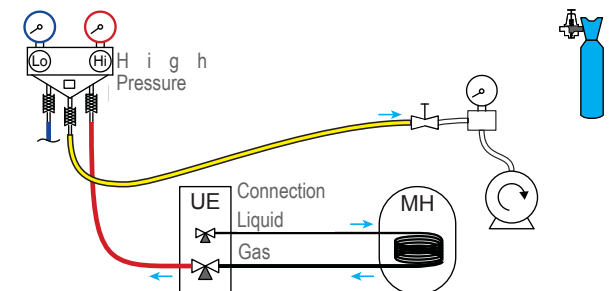

d) Repeat this operation at least three times.

Remember: performing these operations using refrigerant is strictly prohibited.

▼ Seal test

- Remove the protective plug (B) from the filling hole (Schrader) in the gas valve (large diameter).
- Connect the high pressure hose from the *Manifold* to the filling hole (fig. 58).
- Connect the nitrogen bottle to the *Manifold* (only use dehydrated nitrogen type U).
- Fill the refrigeration circuit with nitrogen to maximum 10 bar (**gas-condenser-liquid connection system**).
- Maintain this pressure in the circuit for 30 minutes.

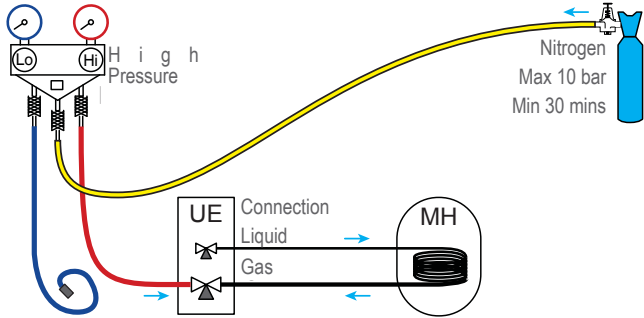

- If a pressure drop occurs, bring it back down to 1 bar and look for leaks with a leak detector, repair and repeat the test.

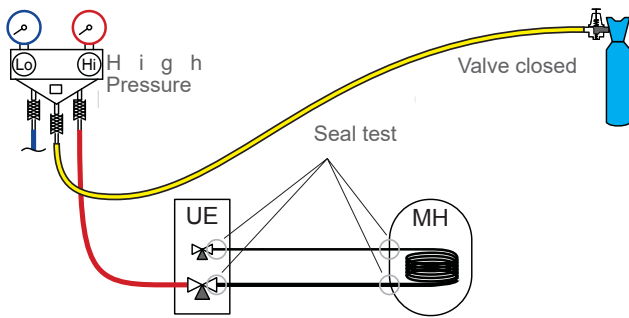

- Once the pressure is steady and there are no leaks, empty the nitrogen by leaving the pressure above atmospheric pressure (between 0.2 and 0.4 bar).

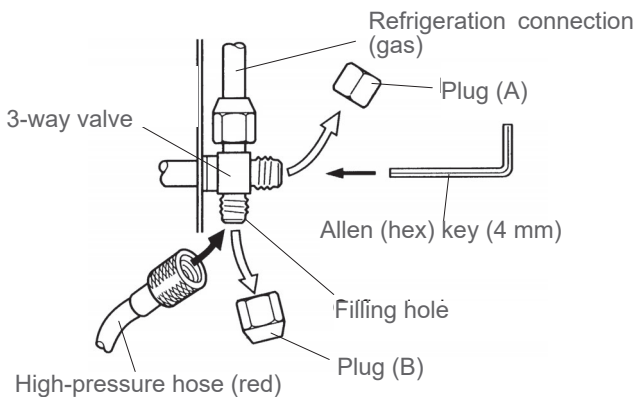

fig. 58 - Connecting the hose to the gas valve

▼ Creating a vacuum



The triple evacuation method (APPENDIX 2) is strongly recommended for any installation and especially when the outdoor temperature is below 10°C.

- If necessary, calibrate the *Manifold* pressure gauge(s) to 0 bar. Adjust the vacuum gauge to current atmospheric pressure (≈ 1013 mbar).
- Connect the vacuum pump to the *Manifold*. Connect a vacuum gauge if the vacuum pump is not equipped with one.

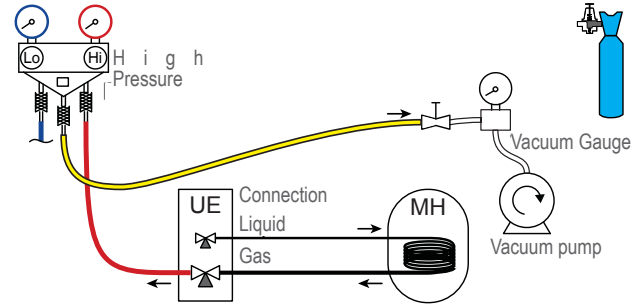

- Create a vacuum until the residual pressure* in the circuit falls below the value given in the following table (* measured with the vacuum gauge).

T °C	5°C < T < 10°C	10°C < T < 15°C	15°C < T
Pmax - bar	0.009	0.015	0.020
- mbar	9	15	20

- Let the pump continue to operate for another 30 minutes minimum after reaching the required vacuum.
- Close the *Manifold* valve, then stop the vacuum pump **without disconnecting any of the hoses in place**.

► Overall hydraulic layout

Installation configuration - see page 51

Parameter  4 - 1 (1 heating circuit)

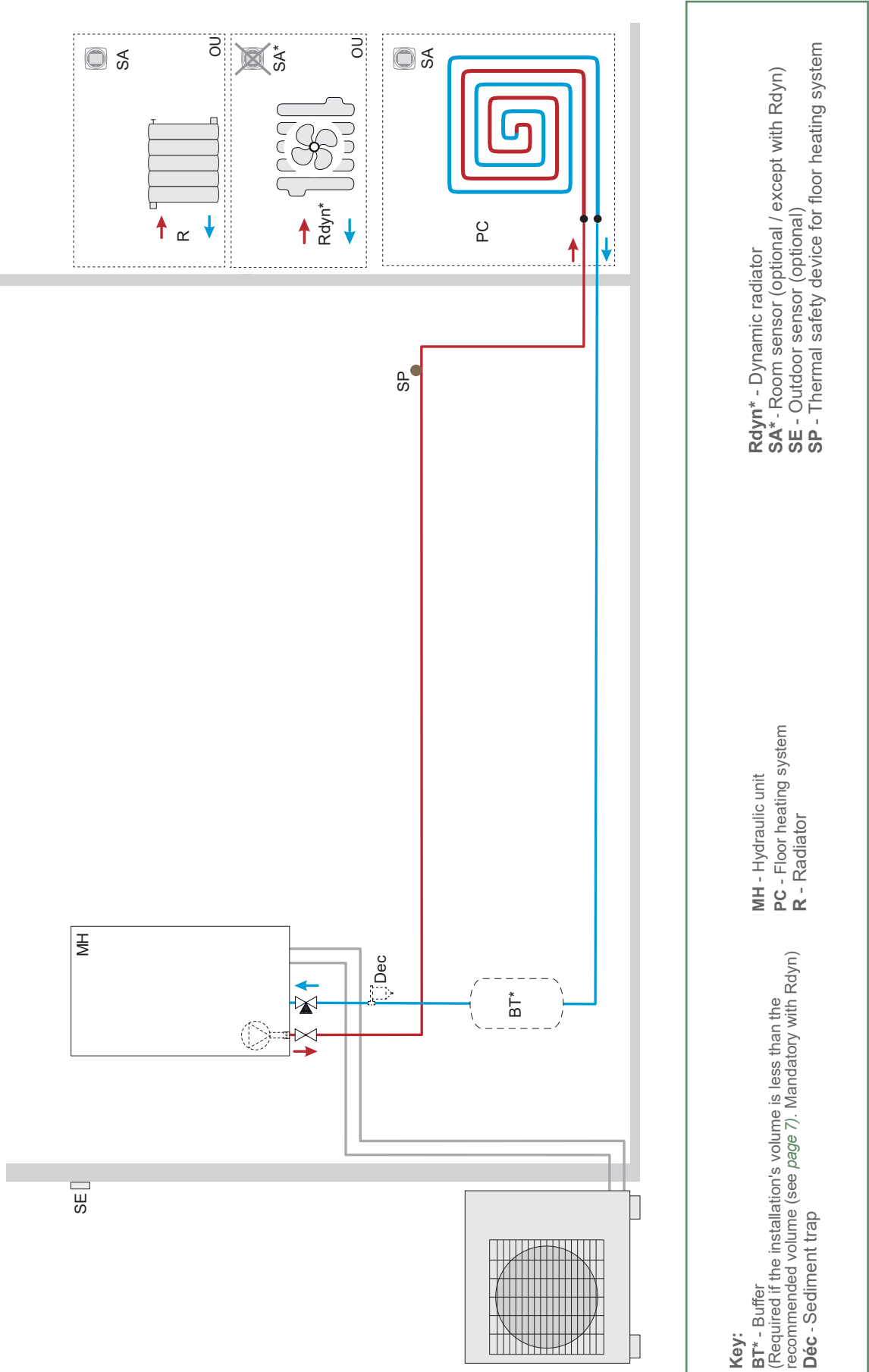

Installation configuration - see page 51

Parameter  4 - 3 (2 heating circuits with decoupling cylinder)

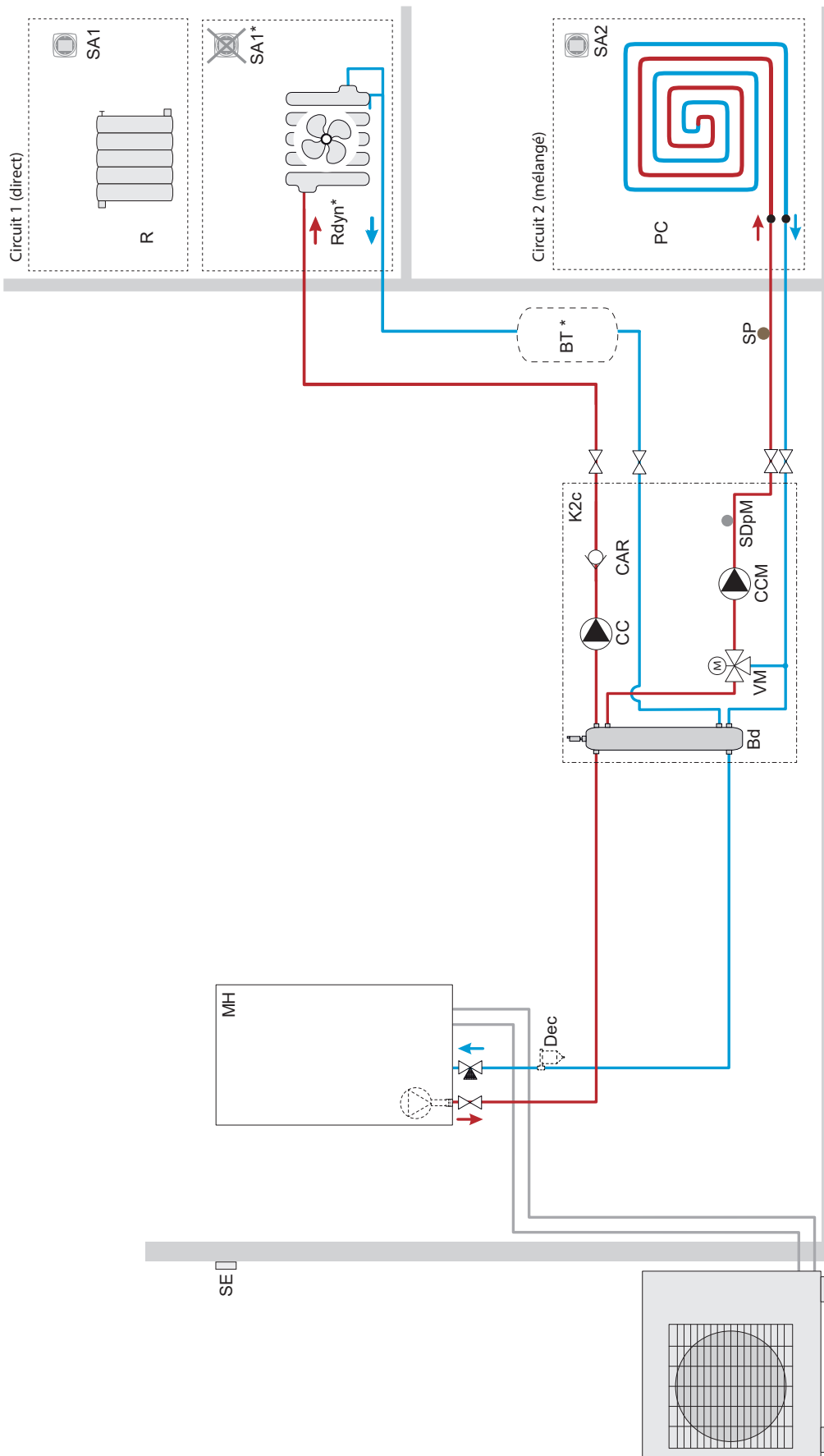

Key:

Bd - Decoupling cylinder

BT* - Buffer

(Required if the installation's volume is less than the recommended volume (see page 7). Mandatory with Rdyn)

CC - Direct circuit circulation pump

CCM - Mixed circuit circulation pump

Déc - Sediment trap

K2C - 2-area kit

MH - Hydraulic unit

PC - Floor heating system

R - Radiator

Rdyn* - Dynamic radiator

SA1/SA2 - Circuit 1/ circuit 2 room sensor (optional) / * except with Rdyn)

SE - Outdoor sensor (optional)

SDpM - Mixed circuit initial flow sensor

SP - Thermal safety device for floor heating system

VM - Mixing valve

Installation configuration - see page 51

Parameter 4 - 1 (1 heating circuit)

Parameter 5 - 1 (DHW tank)

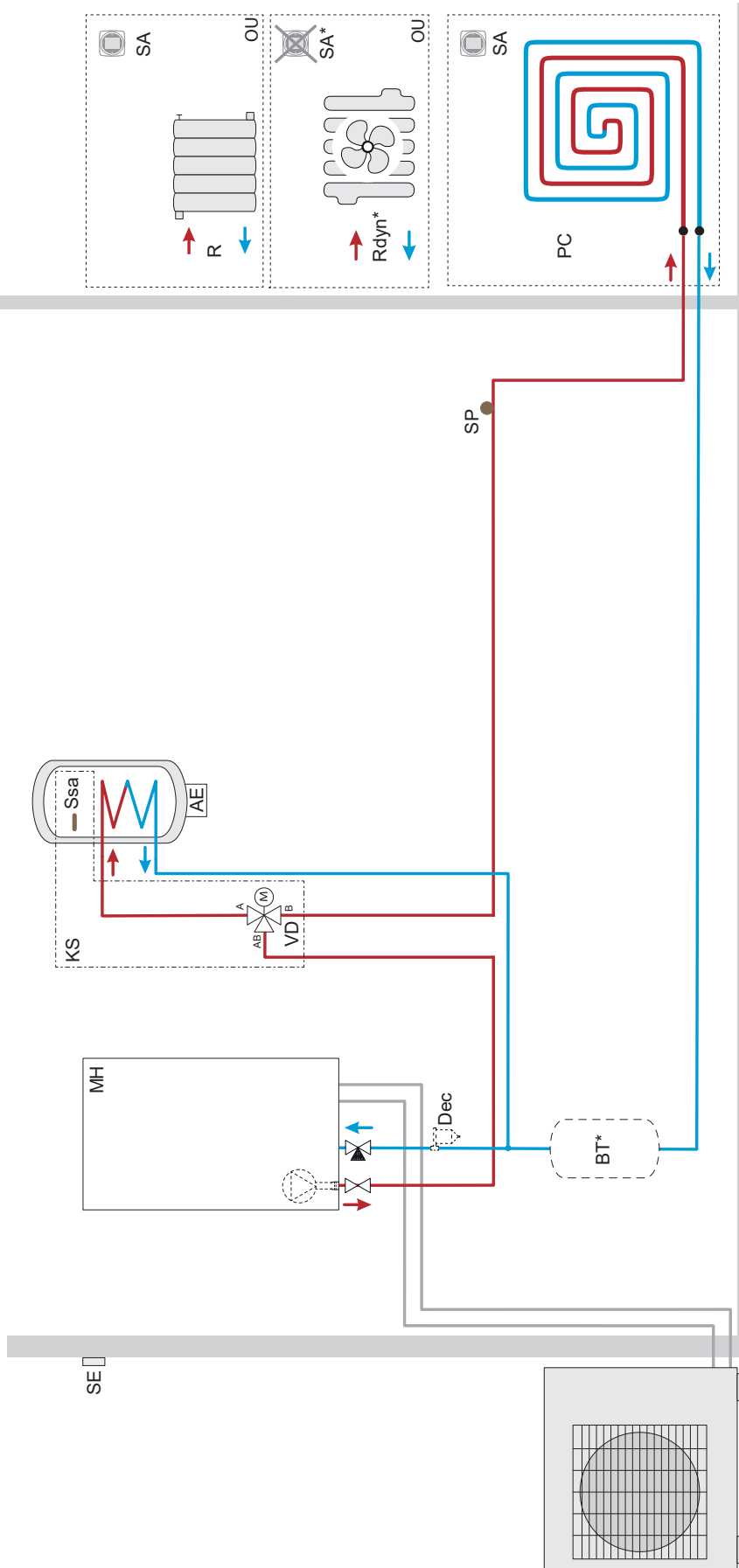

Key:

- AE** - Electrical back-up
- Bd** - Decoupling cylinder
- BT*** - Buffer
(Required if the installation's volume is less than the recommended volume (see page 7). Mandatory with Rdyn)
- CC** - Heating circulation pump

- CCM** - Mixed circuit circulation pump
- Déc** - Sediment trap
- KS** - DHW kit
- MH** - Hydraulic unit
- PC** - Floor heating system
- R** - Radiator

- Rdyn*** - Dynamic radiator
- SA*** - Room sensor (optional / except with Rdyn)
- Ssa** - DHW sensor
- SE** - Outdoor sensor (optional)
- SP** - Thermal safety device for floor heating system
- VD** - Distribution valve

Installation configuration - see page 51

Parameter 4 - 3 (2 heating circuits with decoupling cylinder)

Parameter 5 - 1 (DHW tank)

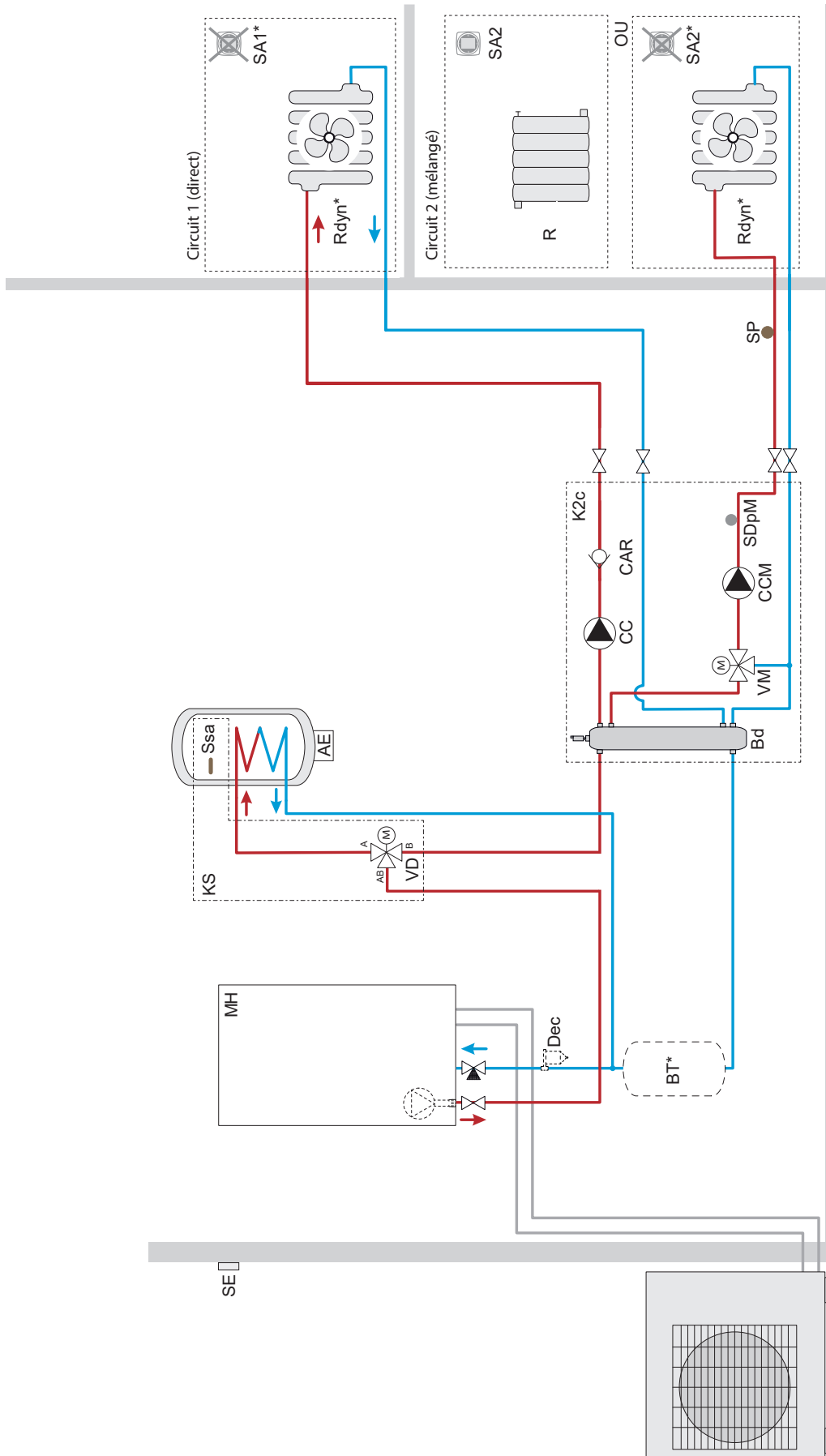

Key:

- AE - Electrical back-up
- Bd - Decoupling cylinder
- BT* - Buffer (Required if the installation's volume is less than the recommended volume (see page 7). Mandatory with Rdyn)
- CC - Direct circuit circulation pump
- CCM - Mixed circuit circulation pump
- Dec - Sediment trap

- K2C - 2-area kit
- KS - DHW kit
- MH - Hydraulic unit
- PC - Floor heating system
- R - Radiator
- Rdyn* - Dynamic radiator
- SA1/SA2 - Circuit 1 / circuit 2 room sensor(optional) / *

- except with Rdyn)
- Ssa - DHW sensor
- SE - Outdoor sensor (optional)
- SDpM - Mixed circuit initial flow sensor
- SP - Thermal safety device for floor heating system
- VD - Distribution valve
- VM - Mixing valve

► Electrical wiring diagrams



Before performing any maintenance, make sure that **all power supplies** have been cut off.

Stored energy: after cutting off the power supplies, wait for 10 minutes before accessing the internal parts of the equipment.



▼ Outdoor unit

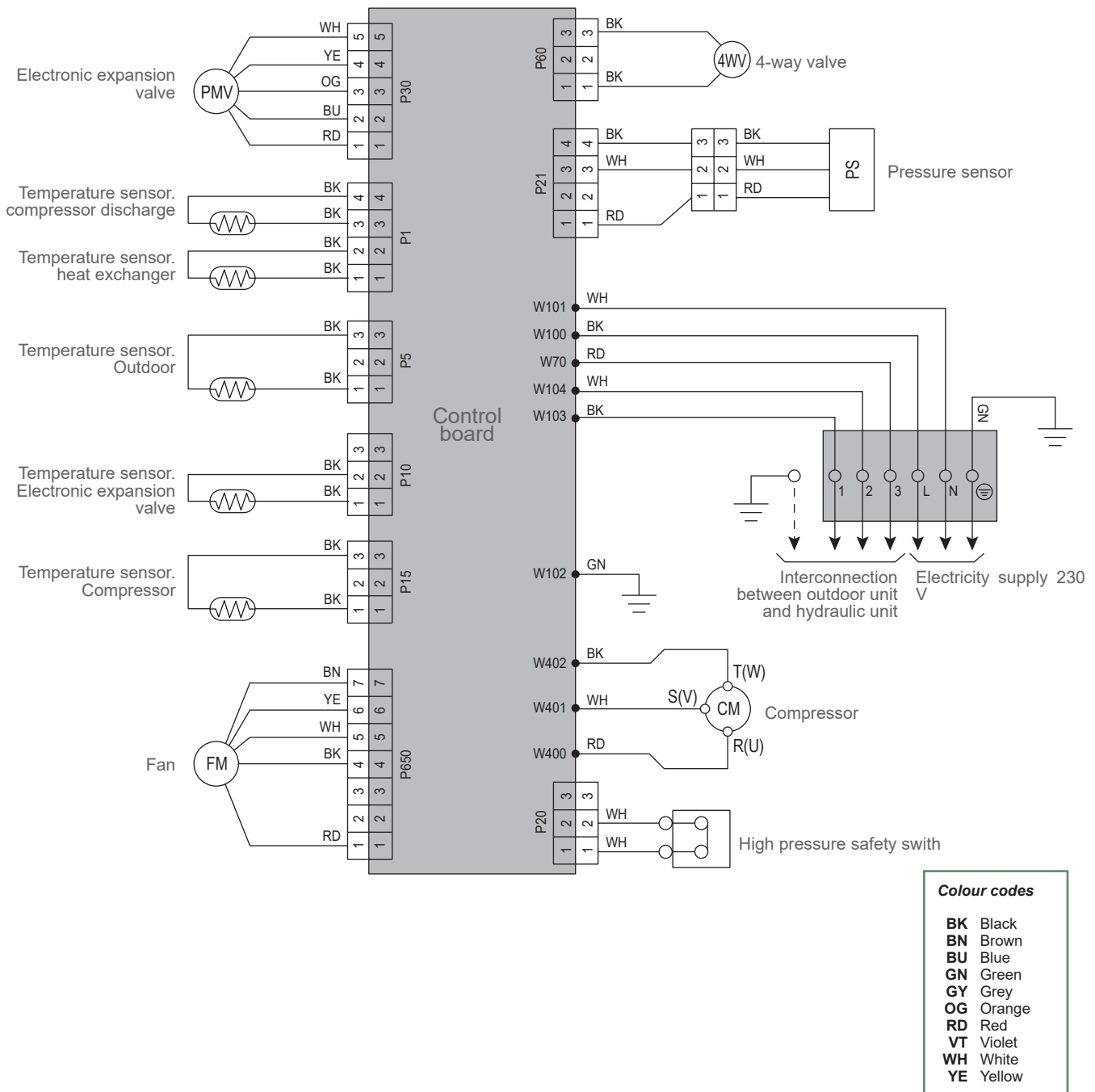

fig. 59 - Electrical wiring of the outdoor unit models 4, 6 and 8

Colour codes

- BK** Black
- BN** Brown
- BU** Blue
- GN** Green
- OG** Orange
- RD** Red
- VT** Violet
- WH** White
- YE** Yellow

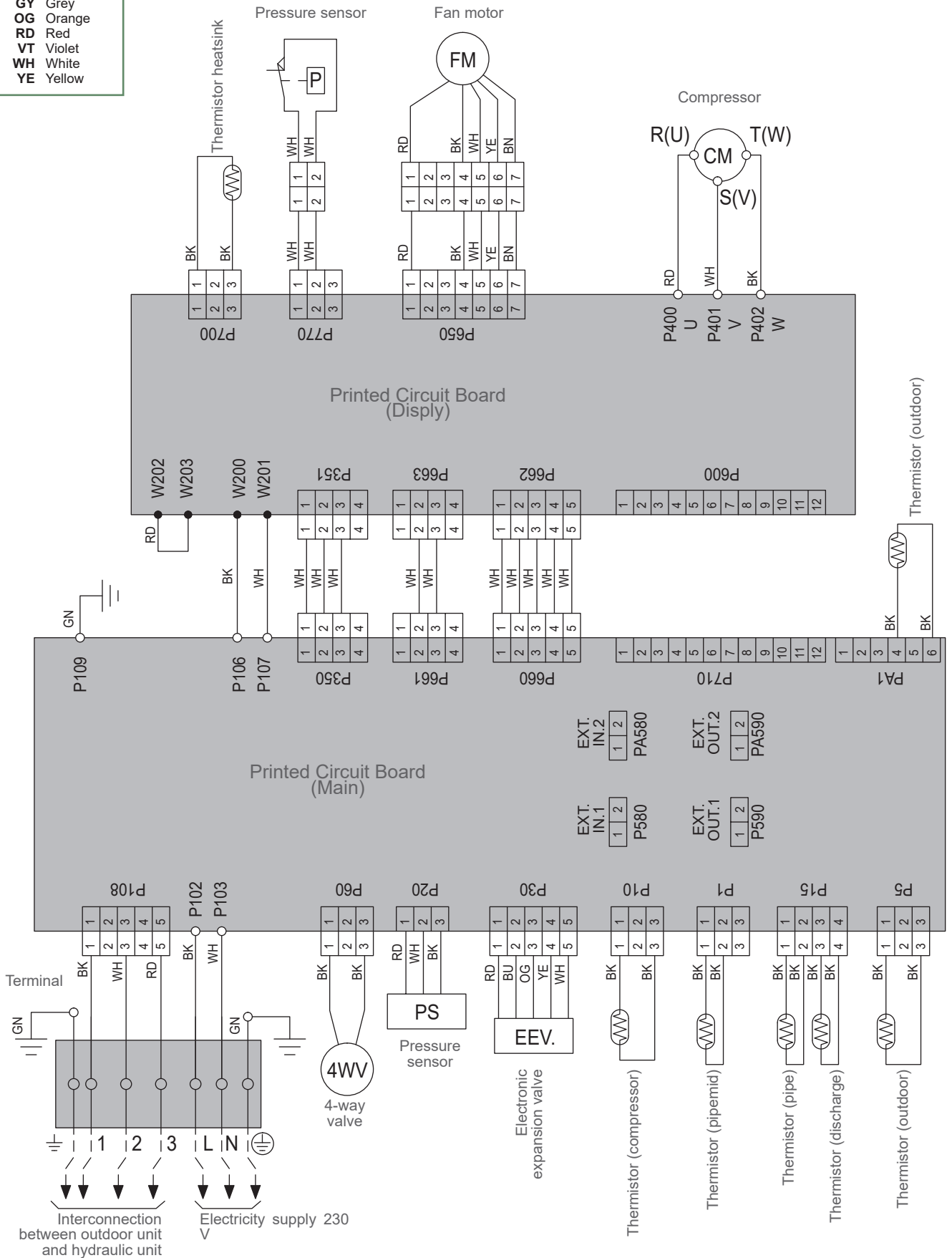
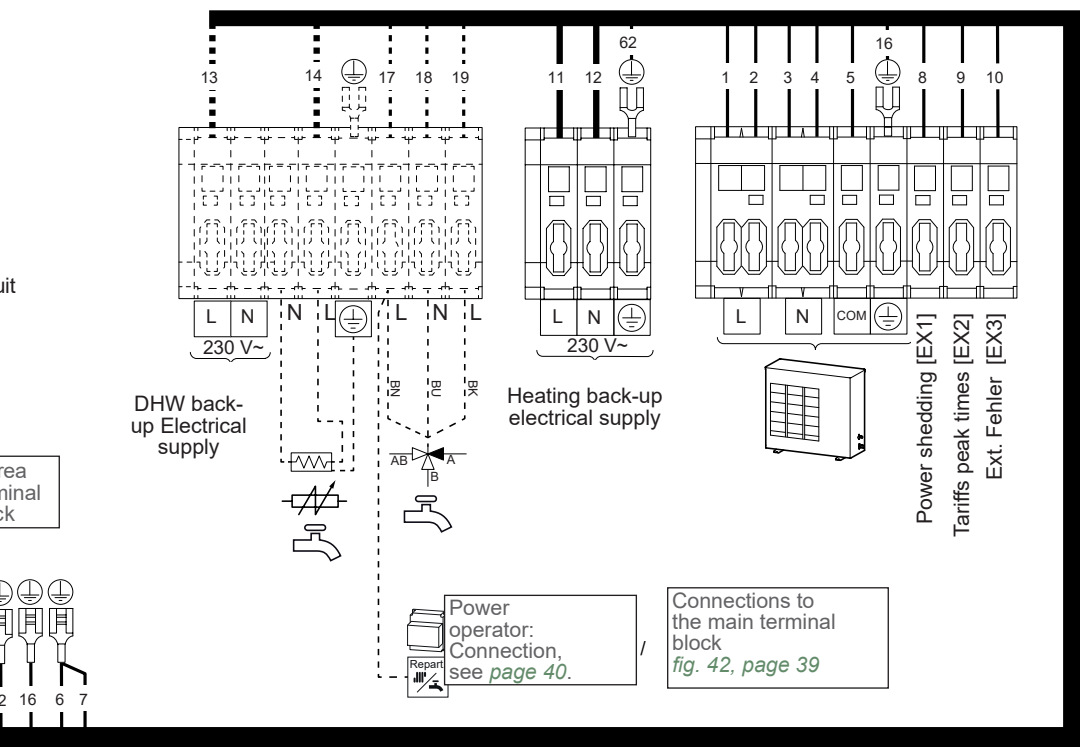
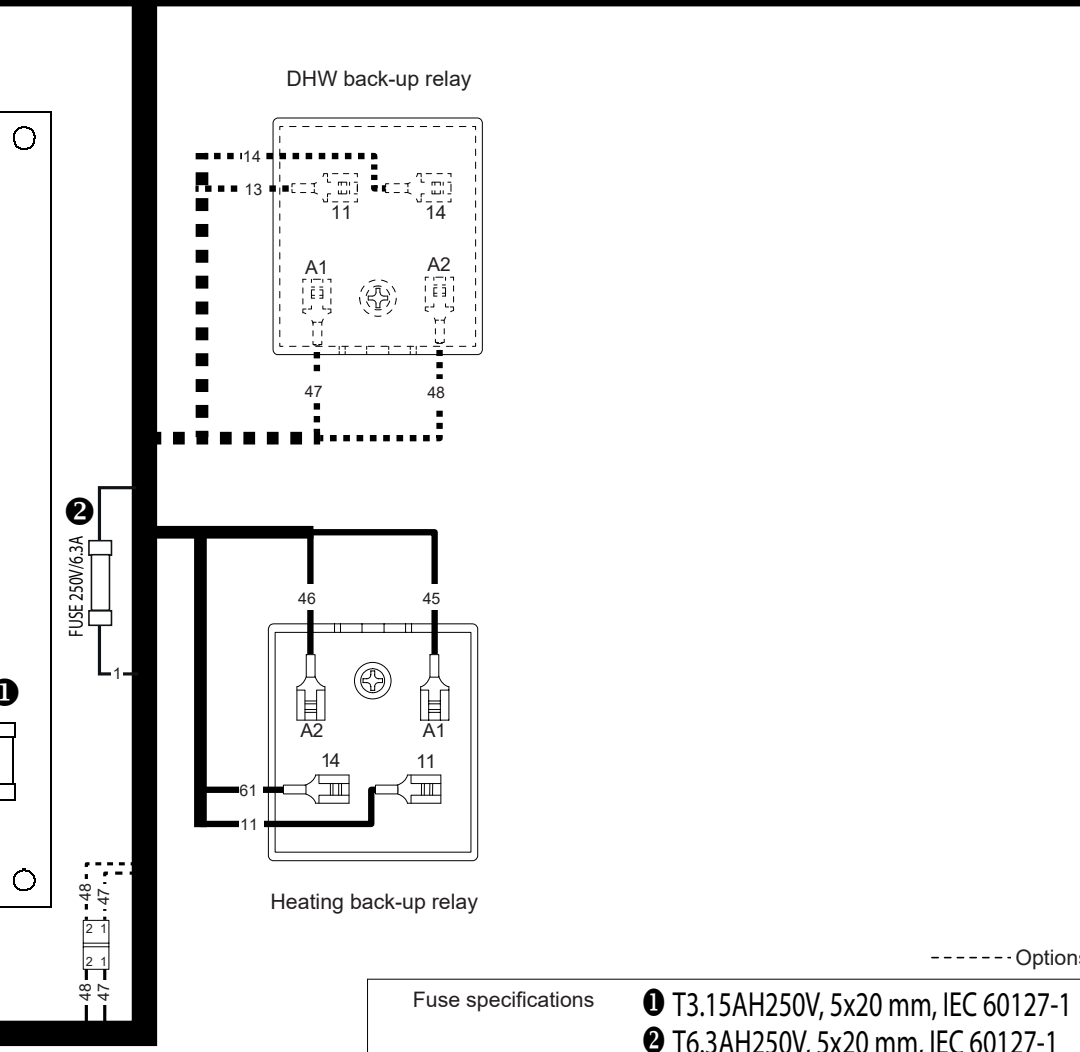

fig. 60 - Electrical wiring of the outdoor unit model 10



Colour codes
 BK black
 BN brown
 BU blue



✓ Quick-start procedure

Before switching on the hydraulic unit :

- Check the electrical cabling.
- Check that the refrigeration circuit is filled with gas.
- Check the hydraulic circuit's pressure (1 to 2 bars), check that the heat pump is drained, along with the rest of the installation.

► Commissioning check-list

▼ Before start-up

	OK	Not compliant
Installation ("□ Layout", page 14)		
Surface, volume and ventilation of the room		
Floor fixing of the hydraulic unit		
Visual checks Outdoor unit (see chapter "Installing the outdoor unit", page 15)		
Location and fittings, condensate evacuation.		
Comply with distances from obstacles.		
Hydraulic checks Hydraulic unit (see chapter "Installation of the hydraulic unit", page 18)		
Connection of pipes, valves and pumps (heating circuit, DHW).		
Installation water volume (expansion vessel of adequate capacity?).		
No leaks.		
Main system pressure and degassing.		
Refrigeration connections and checks (see chapters "□ Refrigeration connections", page 26)		
Check the refrigeration circuits (sealing, no dust or humidity).		
Connections between units (pipe length, flare tightening torque...).		
Mechanical protection of refrigeration connections		
Installation of HP pressure gauges on the gas line (large tube).		
Pump down mandatory.		
Nitrogen leak test (~ 10 bar).		
Opening of refrigeration valves to outdoor unit.		
Filling hydraulic unit and pipes with refrigerant.		
Indicate on the label present on the outdoor unit, the amount of gas (Factory + additional filling)		
Electrical checks Outdoor unit (see chapter "Outdoor unit", page 36)		
Main power supply (230 V).		
Protection by rated circuit breaker.		
Cable dimensions.		
Earth connection.		
Hydraulic unit (see chapter "Hydraulic unit", page 38)		
Connection to outdoor unit (L, N, Earth).		
Sensors connection (positioning and connections).		
Distribution valve connections (boiler and DHW) and circulation pump.		
Power supply and protection of electric backup (option).		

▼ Start-up

	OK	Not compliant
Quick Start Procedure (see chapter "□ Commissioning", page 48).		
Close the installation's main circuit breaker (outdoor unit power supply) 6 hours before testing => Preheating of the compressor.		
The circulator pump and the directional valve start to automatically purge the system.		
Outdoor unit starts after 4 mins.		
Configure Time and Date.		
Configure the hydraulic circuit.		
Adjust the heating gradient.		
Adjust the max flow setpoint.		
Outdoor unit checks		
Operation of fan(s), compressor.		
Current measurement.		
After several minutes measure the difference in air temperature.		
Check condensation and evaporation pressure/temperature.		
Hydraulic unit checks		
After 15 mins of operation.		
Primary water temp. difference.		
DHW priority (switching of distribution valve).		
Operation of heating...		
Control (see chapters "□ Controller Interface", page 44 and "□ Controller Menu", page 50)		
Settings, maintenance, checks.		
Program the heating periods.		
Adjust the setpoints for the heating circuits if different from the default values.		
Setpoint display.		
Explanations of use		



The heat pump is ready for operation !

Some settings (or menus) might not be displayed. They are dependent on the installation's configuration (and installed options).

► Settings sheet

Parameter	Name	Settings
Preliminary settings		
1	hour / minutes	
2	Month - Day	
3	Year	
4	Two heating circuits option	
6	general cooling authorisation	
7	Heating back-up prohibited	
8	DHW back-up prohibited	
35 - 55	Type of emitter	
36	Zone 1 accelerated lowering (only if no room thermostat)	
37 - 57	Mid-season economy	
Heating circuit (HC1 / HC2)		
30 - 50	weather-dependent setpoint slope	
31 - 51	heating curve displacement	
32 - 52	max. initial setpoint	
33 - 53	room T° influence	
Cooling circuit (HC1 / HC2)		
40 - 60	cooling authorisation	
41 - 61	weather-dependent setpoint slope	
42 - 62	heating curve displacement	
43 - 63	min. initial value	
Circulation pump		
70	circulation pump speed	
Domestic hot water		
73	Legionella cycle	

Parameter	Name	Settings
95	DHW forced operation (boost)	
25 => 29	time programmes	
83	DHW max temperature	
Energy counting		
80	EU reference power (see <i>page 54</i>)	
Miscellaneous		
10	Absence mode setpoint	
72	switch between winter/summer	
74	correct outdoor temperature sensor	
75	behaviour of the appliance when suffering from an external error	
77	direction of action input 8 (Load shedding - EX1)	
78	direction of action input 9 (Rates - EX2)	
79	compressor load shedding authorisation	
88 / 89	floor drying	
96	relay test	
97	assist mode	
98	Reset of operating counters	
100	Attenuation mode activation	
Errors (see <i>page 58</i>)		
Outdoor unit errors (see <i>page 60</i>)		

Some settings (or menus) might not be displayed. They are dependent on the installation's configuration (and installed options).

► Start-up data sheet

Worksite				Installer			
Outdoor unit	Serial No.			Hydraulic unit	Serial No.		
	Model				Model		
Type of refrigerant				Refrigerant charge		kg	
Checks				Voltages and currents in operation on the outdoor unit			
Compliance with positioning distances				L/N	V		
Correct condensate discharge							
Electric connections / connections tightened				L/T	V		
No GAS leaks (unit ID No.:)							
Correct installation of refrigerant connection (length m)				N/T	V		
Reading in HOT operation							
Compressor discharge temperature		°C		Icomp	A		
Fluid line T°		°C					
Condensation T°	HP = bar	°C		Sub-cooling		°C	
Tank water output T°		°C		Condensation ΔT°		°C	
Tank water inlet T°		°C		Secondary ΔT°		°C	
Evaporation T°	BP = bar	°C		Overheating		°C	
Aspiration T°		°C		Evaporation ΔT°		°C	
Battery air inlet T°		°C		Battery ΔT°		°C	
Battery air output T°		°C					
Hydraulic network on hydraulic unit							
Secondary network	Underfloor heating			Circulation pump brand	Type		
	LT radiators						
	Fan-coil heaters						
Domestic hot water; tank type							
Secondary network water volume estimate				L			
Options & accessories:							
Power supply for electrical back-up				Room thermostat			
Location of room sensor correct							
dual-circuit kit							
DHW kit							
Cooling kit							
				Details			
Control settings							
Type of configuration							
Key parameters							

Instructions for the user

Explain to the user how the installation operates, in particular the functions of the room thermostat and the programmes accessible via the user interface.

Emphasise that a heated floor has significant inertia and that therefore any adjustments must be made progressively.

Also explain to the user how to check the filling of the heating circuit.

End of life of the device

The apparatus must be dismantled and recycled by a specialised service provider.

The apparatus must never be disposed of with household waste, large objects or in a landfill.

When the apparatus reaches its end of life, please contact your installer or the local representative in order to proceed with the dismantling and recycling of this apparatus.

Date de la mise en service :

Coordonnées de votre installateur chauffagiste ou service après-vente.



This appliance is marked with this symbol. It means that all electrical and electronic products must be strictly separated from household waste. A specific recovery system for this type of product is in place in the countries of the European Union (*), Norway, Iceland and Liechtenstein. Do not attempt to dismantle this product yourself. This can have adverse effects on your health and on the environment. Refrigerant liquid, oil and other parts must be reprocessed by a qualified installer in accordance with applicable local and national laws. In terms of recycling, this appliance must be processed by a specialised service and must not, under any circumstances, be thrown out with household waste, bulky waste or at a tip. Please contact your installer or local representative for more information.

* Depending on the national regulations of each member state.



This appliance conforms to:

- the low voltage directive 2014/35/UE, under standard EN 60335-1, EN 60335-2-40, EN 60529 and EN 60529/A2 (IP),
- the electromagnetic compatibility directive 2014/30/UE,
- the machinery directive 2006/42/EC,
- the directive for pressurised equipment 2014/68/UE,
- the eco-design directive 2009/125/EC,
- the energy labelling directive 2010/30/EC,

This appliance also complies with:

- decree No. 92-1271 (and its modifications) relating to certain refrigeration fluids used in refrigeration and air conditioning equipment.
- regulation 842/2006 of the European parliament on certain fluorinated greenhouse gases.
- the standards relating to the product and the testing methods used: Air-conditioners, refrigeration units and heat pumps with compressor driven by electric motor for heating and refrigeration EN 14511-1, 14511-2, 14511-3, and 14511-4.
- standard EN 12102: Air-conditioners, heat pumps and dehumidifiers with compressor driven by electric motor. Measurement of airborne noise. Determination of acoustic power level.



Keymark Certification :

- 012-C700121 - Loria 6004 R32
- 012-C700122 - Loria 6006 R32
- 012-C700123 - Loria 6008 R32
- 012-C700124 - Loria 6010 R32